



ED 100

ED 250

# Swing door drives in modular design

With their ED 100 and ED 250 swing door drives, dormakaba offers electromechanical swing door drives for various fields of application. Simply select the suitable version according to your prevailing door-leaf width and weight: While the ED 100 is suitable for doors with a weight of up to 160 kg or a door width of 1,100 mm, the ED 250 is designed for doors with a width of 1,600 mm or a door weight of 400 kg.

Apart from the extended cover, dormakaba also provides an easy-to-install integrated door coordinator. With the aid of the dormakaba Upgrade Cards, the system's functional range may be adapted to various door versions. The large scope of integrated functions furthermore ensures that the majority of possible applications may easily be realized.

## Application: ED 100/ED 250

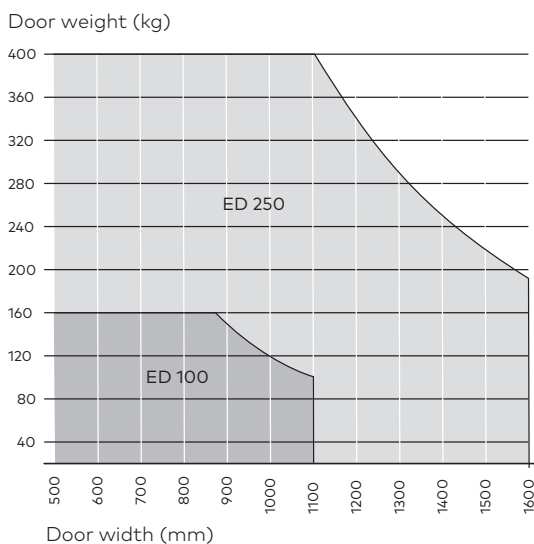

## Benefits

- Flexible configuration: Customers only pay for the functions they actually require.
- Cheap transport and easy mounting thanks to the system's reduced weight.
- Low-noise application due to multi-stage gear.
- Elegant visual appearance: dormakaba Contur design provides a drive height of only 70 mm.
- Various functions as standard.

## Fields of application

- For single- or double-leaf swing doors. Choose between the ED 100 and the ED 250 in accordance with your prevailing door-leaf width and weight.
- The pull-version with slide channel and the push-version with standard arm are suitable for application at fire and smoke doors.
- Thanks to its low- and full-energy version, the system is suitable to automate both rarely and heavily frequented internal and external doors.
- High torque for full-automatic swing doors with radar motion control.
- For interior and exterior doors.

The drives ED 100 and ED 250 are suitable for most swing doors provided that the combination of door width and door weight lies within the defined functional area.

This diagram allows you to determine the maximum values for the door width or door weight or to determine the suitable drive for existing doors.

All values apply to an ideal door. The achievable speed is to be lowered for heavy doors in order to ensure the safety of people.

Additional door components such as door hinges, seals, locks or other mechanical components may restrict the functional area.

The specifications are valid up to a lintel depth of 300 mm; at a depth > 301 mm the door panel weight of the ED 250 is reduced to 160 kg irrespective of the door width.

Use the door weight calculator<sup>1)</sup> for a detailed door planning.



## Our commitment to a sustainable future

We are committed to sustainable development as one of our business maxims. dormakaba's aim is to ensure energy-saving and resource-conserving production, a high recycling ratio and the longevity of our quality products. Environmental Product Declarations (EPD), based on a holistic life cycle assessment, are used for the calculation of the sustainability of buildings. EPD certificates are on [www.dormakaba.com](http://www.dormakaba.com) available.

<sup>1)</sup> Door weight calculator at <http://www.dorma.com/de/de/inspirationen-loesungen/im-fokus/ed-planungsrechner/index.html>

**Required operating conditions**

Ambient temperature	-15 to +50 °C
Only suitable for dry environments	Relative humidity max. 93 % (non condensing)
Power supply	230 V AC 50 Hz +/- 10 %
Class of protection	IP 20

**General specifications**

Dimensions (W x H x D)	685 x 70 x 130 mm
Min. clearance between hinges (double-leaf systems)	1,400 mm
Min. clearance between hinges for ESR (double-leaf systems)	1,450 mm
Weight of single-leaf version	12 kg
Power supply for external accessories	24 V DC +/- 10 %, 1.5 A
Opening angle	Max. 110°
Manufactured to ISO 9001	yes
Environmental product declaration in accordance with ISO 14025	yes
Programme holder: Institute Construction and Environment e.V.	
Declaration number: EPD-DOR-2012211-E	

**Integrated functions**

Hold-open time	30 s, 180 s (optional)
Blocking behavior	Reversing/Door closer function
Locking feedback contact	Motor lock
Wind load control	up to 150 N
Voltage-independent braking circuit	Adjustable via potentiometer
Electronic latching action pulse	Force adjustable
LED status indicator	green Operating voltage indicator
	red Malfunction indicator
	yellow Service interval indicator
Integrated program switch	OFF
	AUTOMATIC
	PERMANENT OPEN
	EXIT ONLY (only for single-leaf systems)
User interface with information display	Status indicator and parameterisation
Slot for dormakaba Upgrade Cards	Extension of functional range
Update interface	Firmware update
TMP – Temperature Management Program	Temperature-related overload protection
IDC – Initial Drive Control	Driving phase optimisation
Cycle counter	0 – 1,000,000 (reasonably subdivided)
Power Assist function	Servo-supported when opened manually
Push & Go function	Door opens when moved manually by 4°

**Inputs, terminals max. 1.5 mm<sup>2</sup>**

Potential-free activator	Inside and outside (NO contact)
Energized activator	8 – 24 V DC/AC + 10 %
Night-/Bank (key switch)	NO contact/NC contact
Safety sensor	Hinge side and opposite hinge side (NC contact)
Test signal for safety sensor	Hinge side and opposite hinge side
Emergency-Off pushbutton/ Lock switch	NC contact/NO contact

**Outputs, terminals max. 1.5 mm<sup>2</sup>**

Potential-free door status contact, alternatively	Door closed
	Door open
	Malfunction

**ED 100**

Max. power consumption	120 Watts
Closing force EN 1154	EN 2–4, adjustable
Max. door-leaf weight for lintel depths of up to 300 mm	160 kg depending on the door width
Door-leaf width	700–1,100 mm
Opening speed 0 – 90°	4* – 12 seconds
Closing speed 90 – 0°	5* – 21 seconds
Axle extension	20/30/60 mm
Lintel depth for slide channel	+/- 30 mm
Lintel depth for slide channel CPD	30 – 60 mm
Lintel depth for standard arm	0–300 mm

**ED 250**

Max. power consumption	240 Watts
Closing force	EN 4–6, adjustable
Max. door-leaf weight for lintel depths of up to 300 mm	400 kg depending on the door width
Max. door-leaf weight for lintel depths from 301 mm to 500 mm	160 kg
Door-leaf width	700 – 1,600 mm
Door-leaf width for fire protection doors	700 – 1,400 mm
Opening speed 0 – 90°	3* – 12 seconds
Closing speed 90 – 0°	4* – 21 seconds
Axle extension	20/30/60/90 mm
Lintel depth for slide channel	+/- 30 mm
Lintel depth for slide channel CPD	30 – 60 mm
Lintel depth for standard arm	0 – 500 mm
For lintel depths standard arm for fire protection	0 – 350 mm

\* Depending on the door panel weight, it is automatically limited in the low-energy operating mode according to EN 16005 or DIN 18650, BS 7036-4 and ANSI 156.19. Max. speeds are achieved only in the full-energy mode, with a low door panel weight and a taught opening angle of at least 95°.

**View: BASIC cover, pull-version, 12.5 mm pivot pin, standard axle extension**

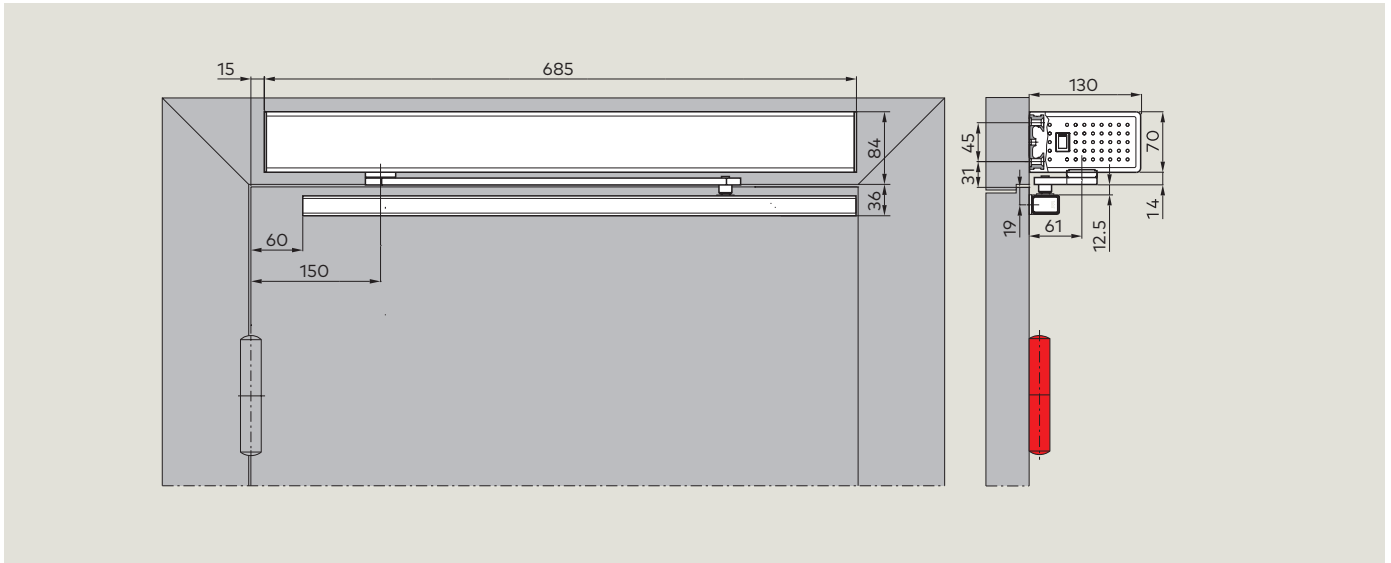

**View: BASIC cover, pull-version, 25 mm pivot pin, standard axle extension**

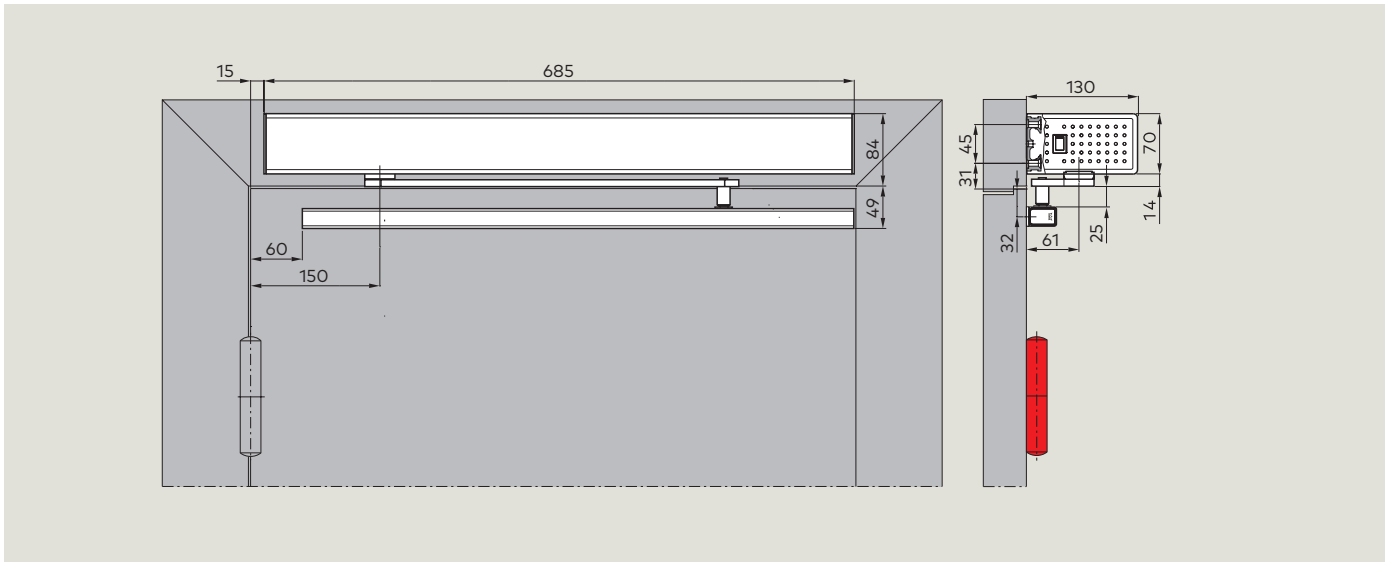

Drilling template: BASIC cover, pull-version, 12.5 mm pivot pin, standard axle extension

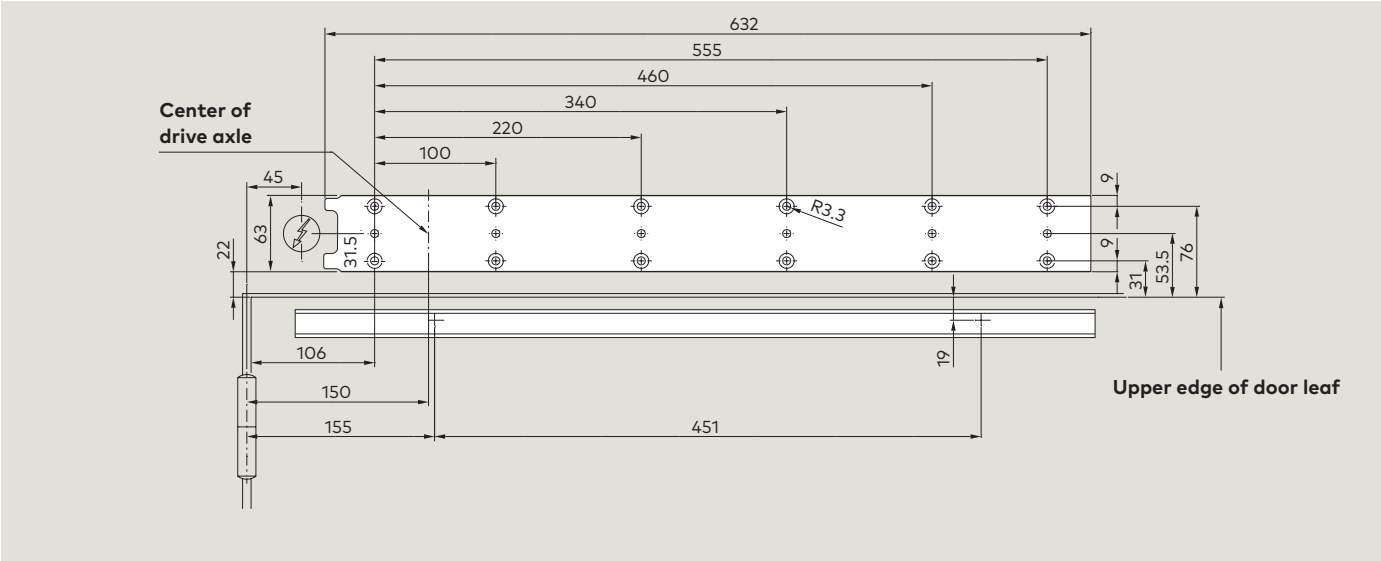

Drilling template: BASIC cover, pull-version, 25 mm pivot pin, standard axle extension

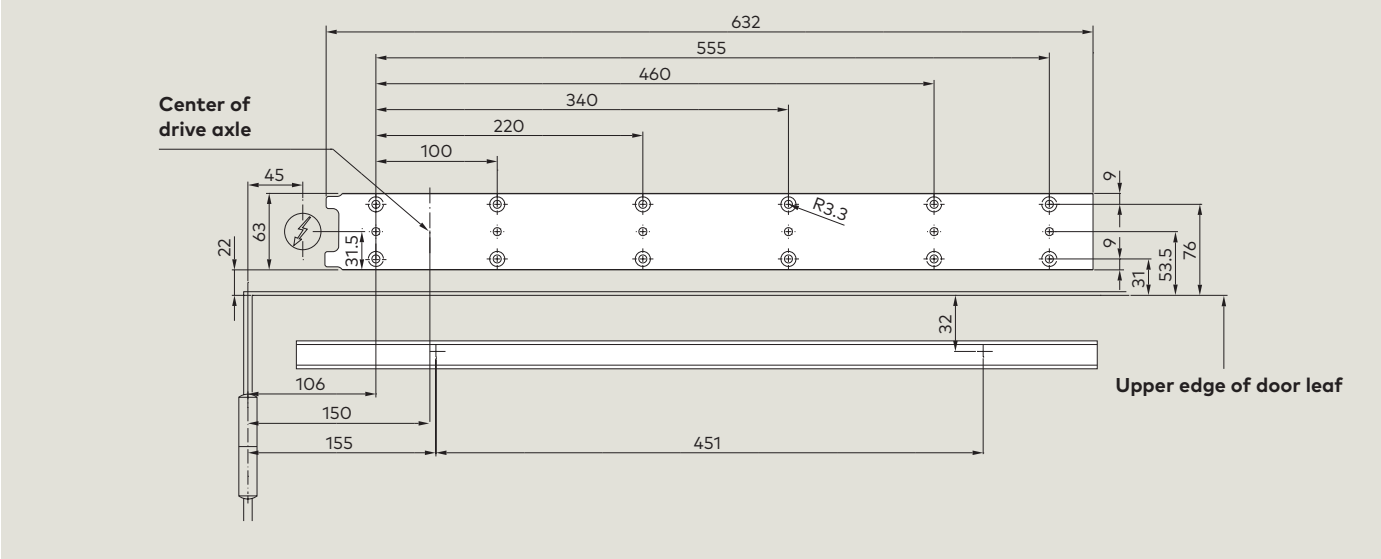

**View: BASIC cover, pull-version, CPD arm, 12.5 mm pivot pin, standard axle extension**

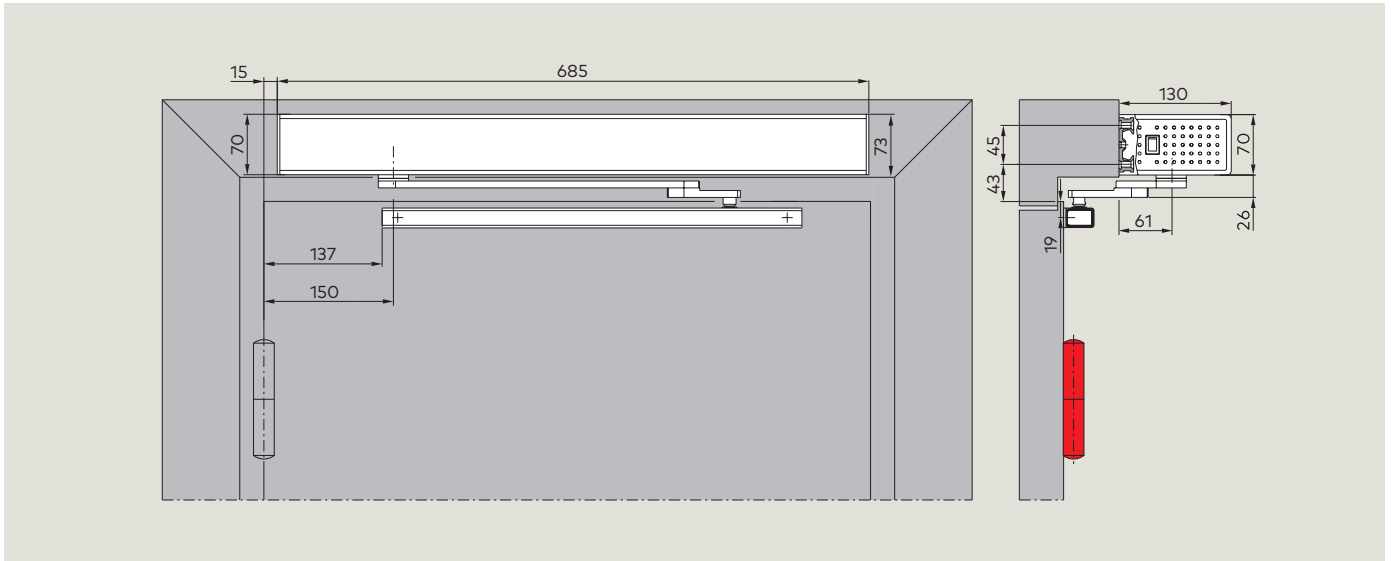

**View: BASIC cover, pull-version, CPD arm, 25 mm pivot pin, standard axle extension**

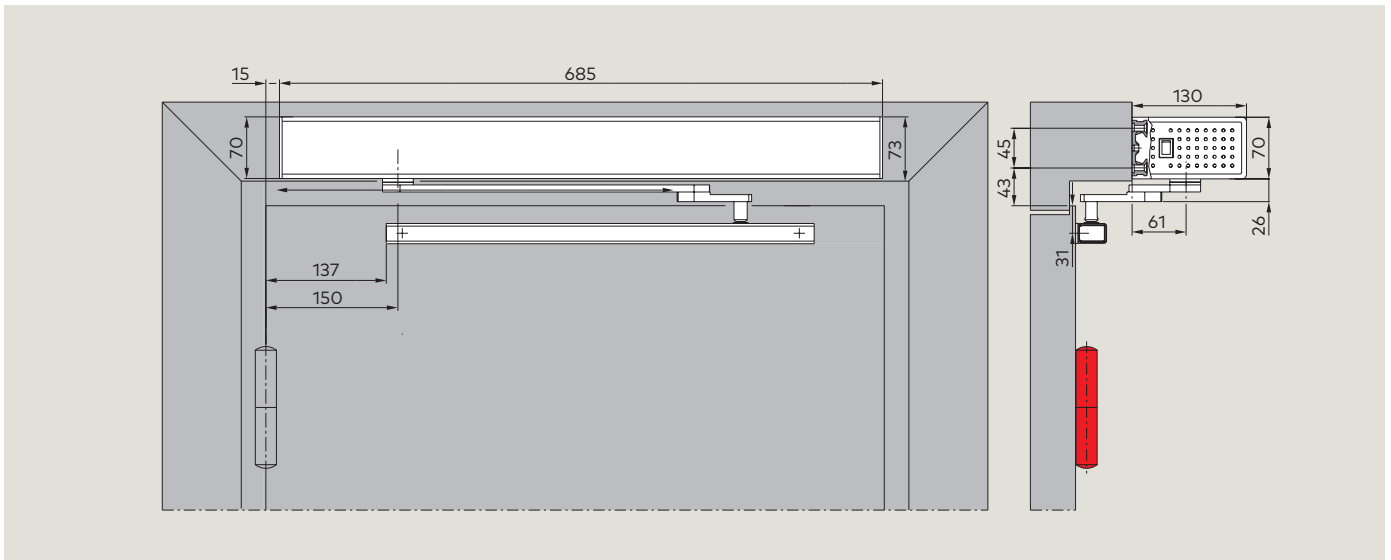

Drilling template: BASIC cover, pull-version, CPD arm, 12.5 mm pivot pin, standard axle extension

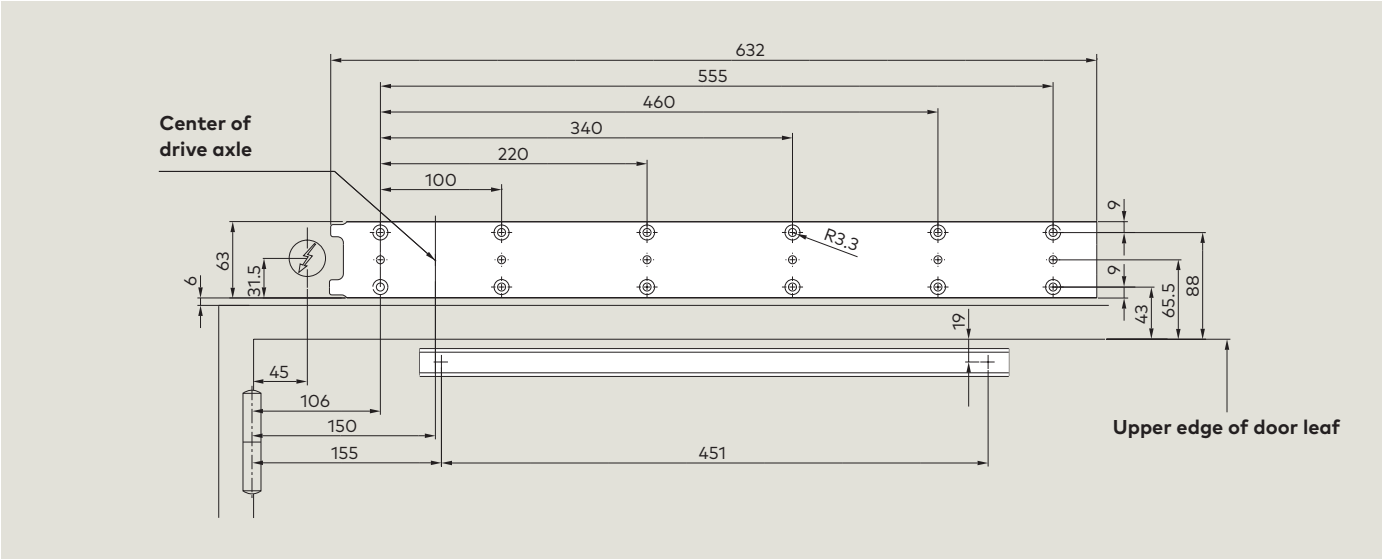

Drilling template: BASIC cover, pull-version, CPD arm, 25 mm pivot pin, standard axle extension

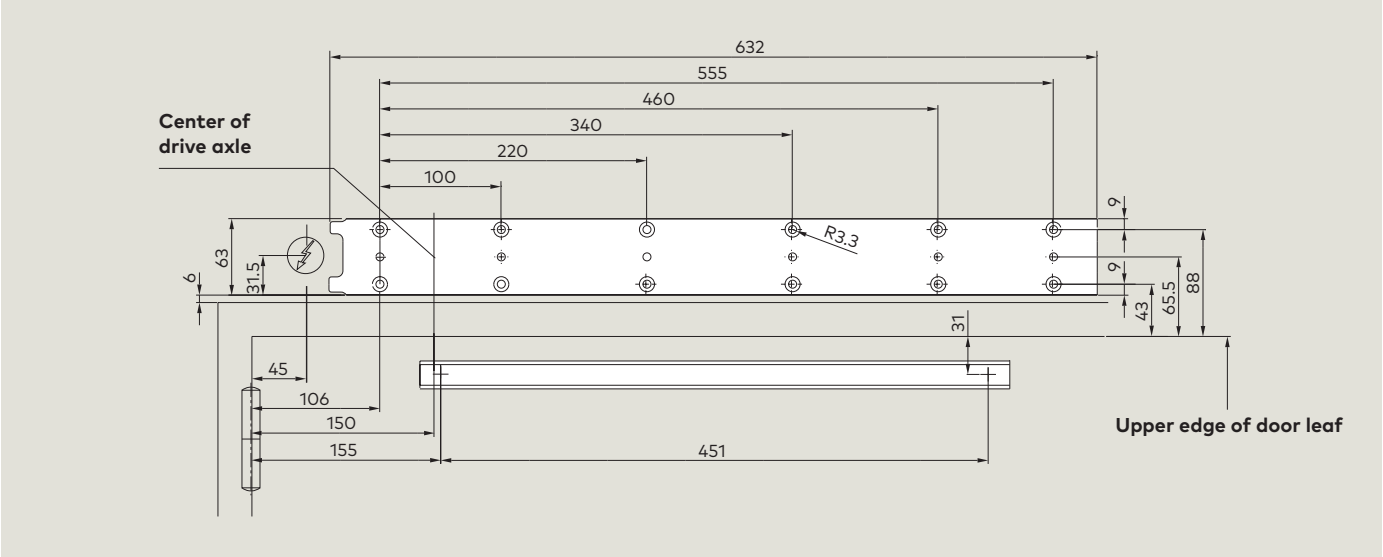

**View: BASIC cover, push-version, 12.5 mm pivot pin, standard axle extension**

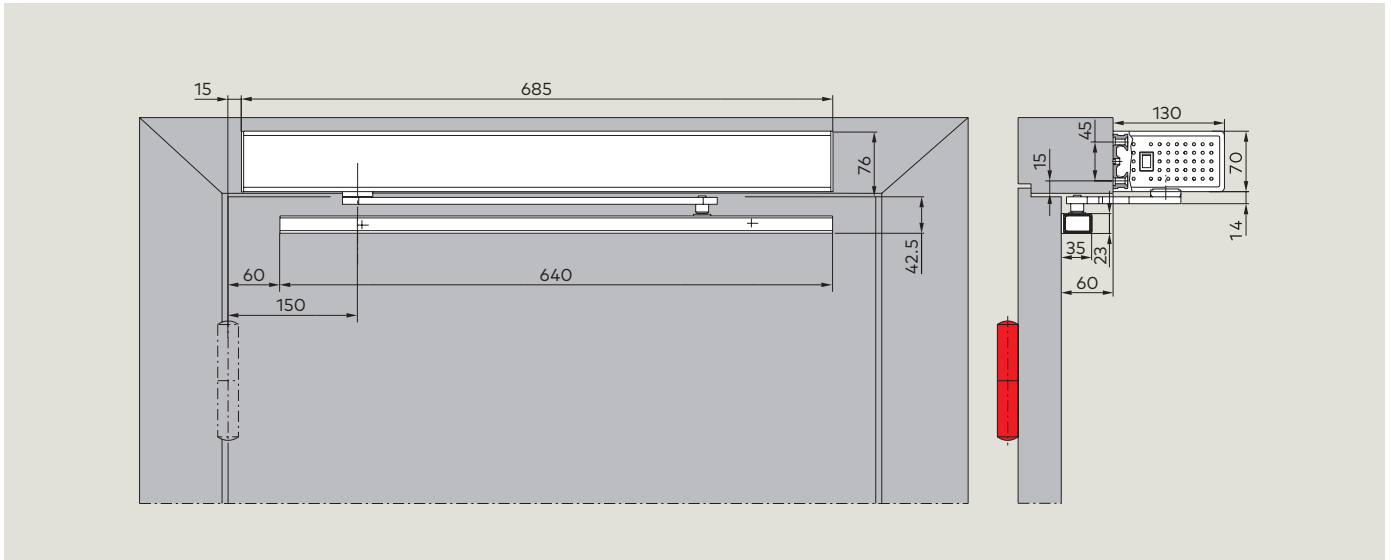

The push-version with slide channel is not suitable for smoke control doors and fire doors

**View: BASIC cover, push-version, 25 mm pivot pin, standard axle extension**

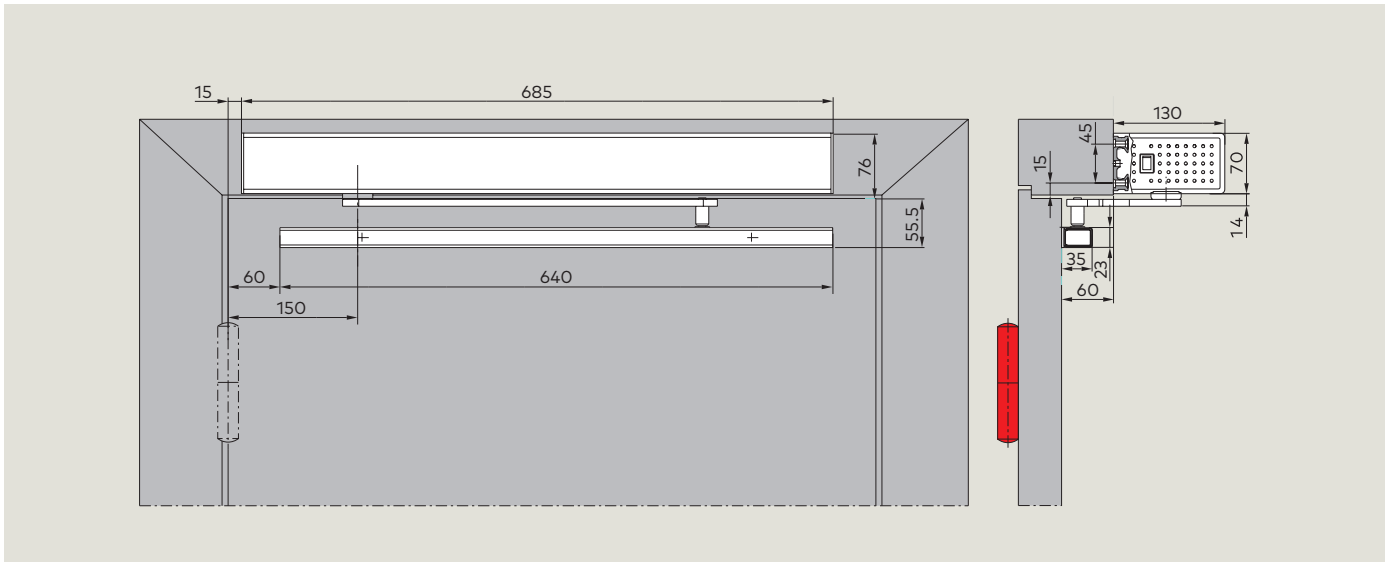

The push-version with slide channel is not suitable for smoke control doors and fire doors

**View: BASIC cover, push-version, standard axle extension**

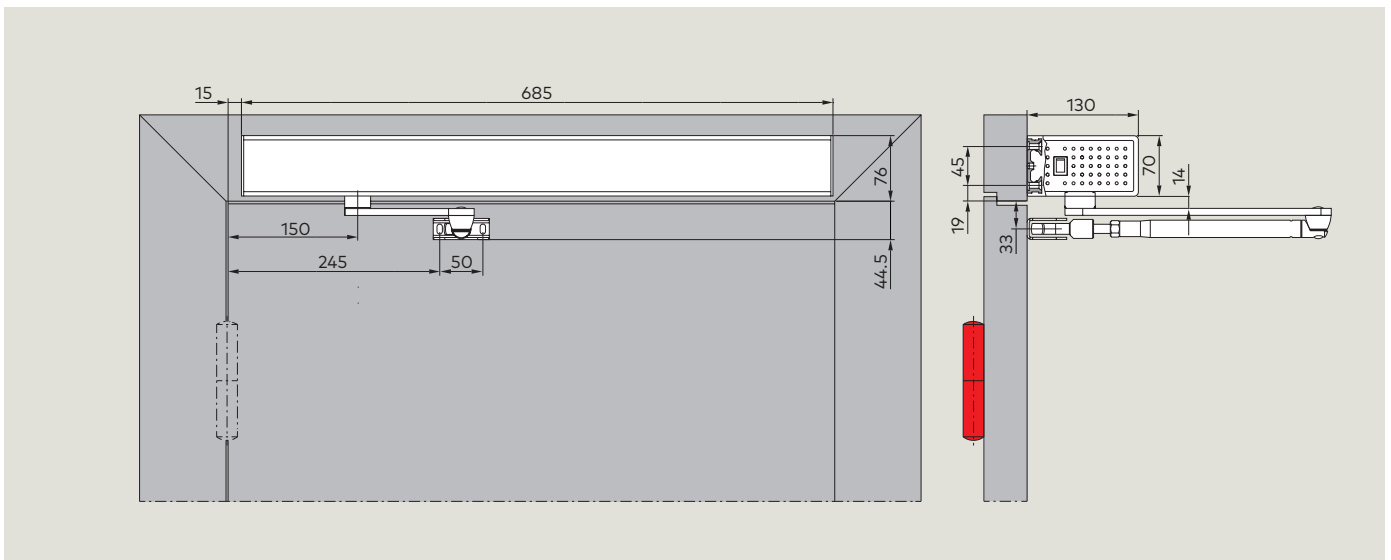



**Drilling template: BASIC cover, push-version, 12.5 mm pivot pin, standard axle extension**

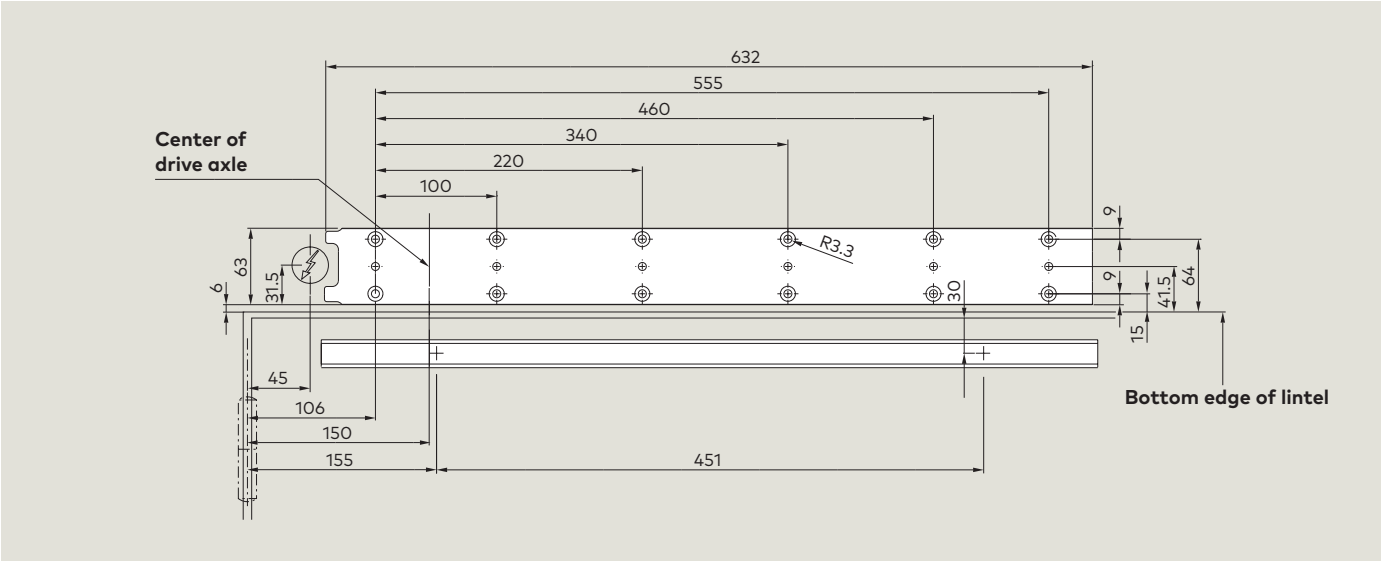

The push-version with slide channel is not suitable for smoke control doors and fire doors

**Drilling template: BASIC cover, push-version, 25 mm pivot pin, standard axle extension**

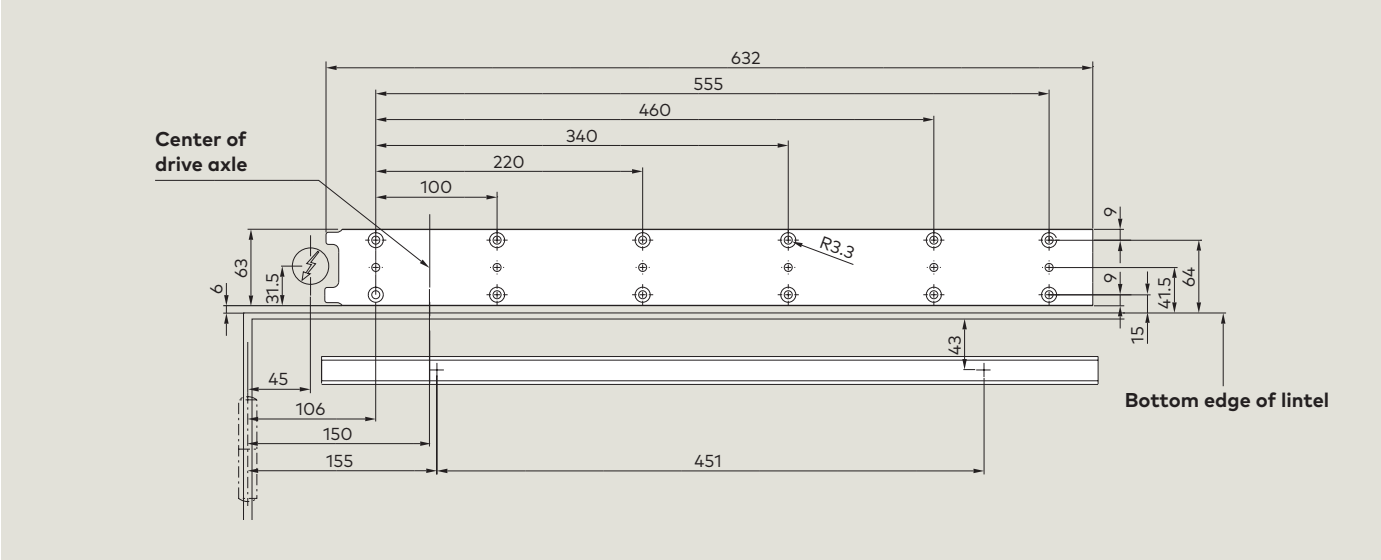

The push-version with slide channel is not suitable for smoke control doors and fire doors

**Drilling template: BASIC cover, push-version, standard axle extension**

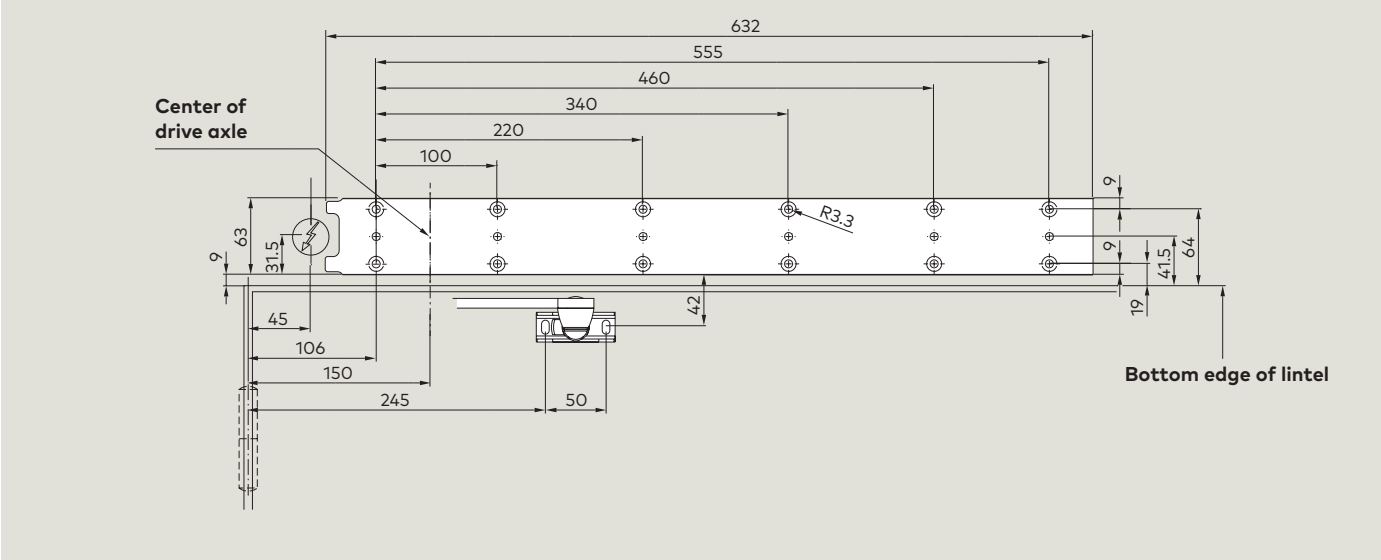

View: PROFESSIONAL cover, pull-version, 12.5 mm pivot pin, standard axle extension

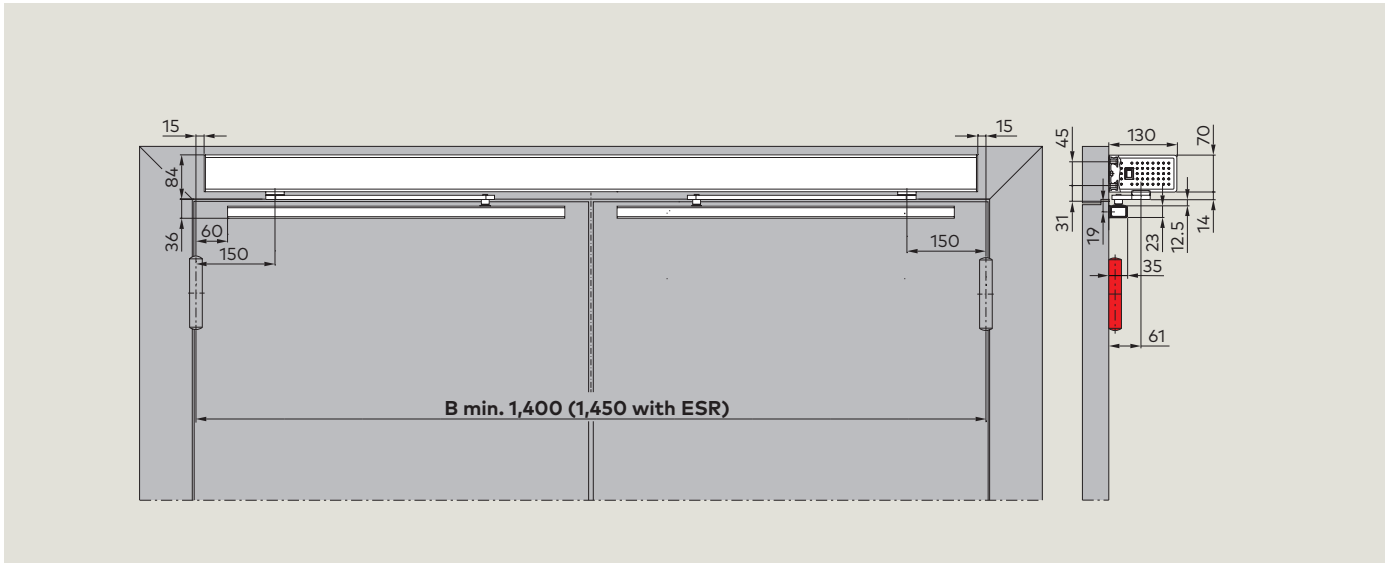

View: PROFESSIONAL cover, pull-version, 25 mm pivot pin, standard axle extension

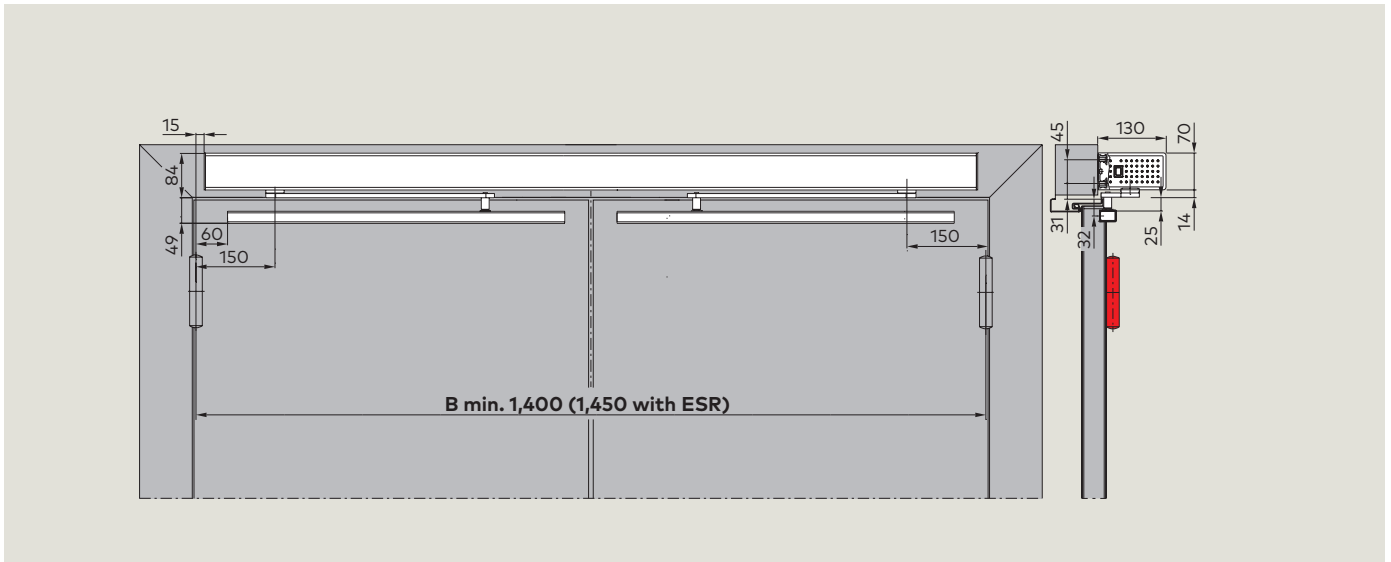

Drilling template: PROFESSIONAL cover, pull-version, 12.5 mm pivot pin, standard axle extension

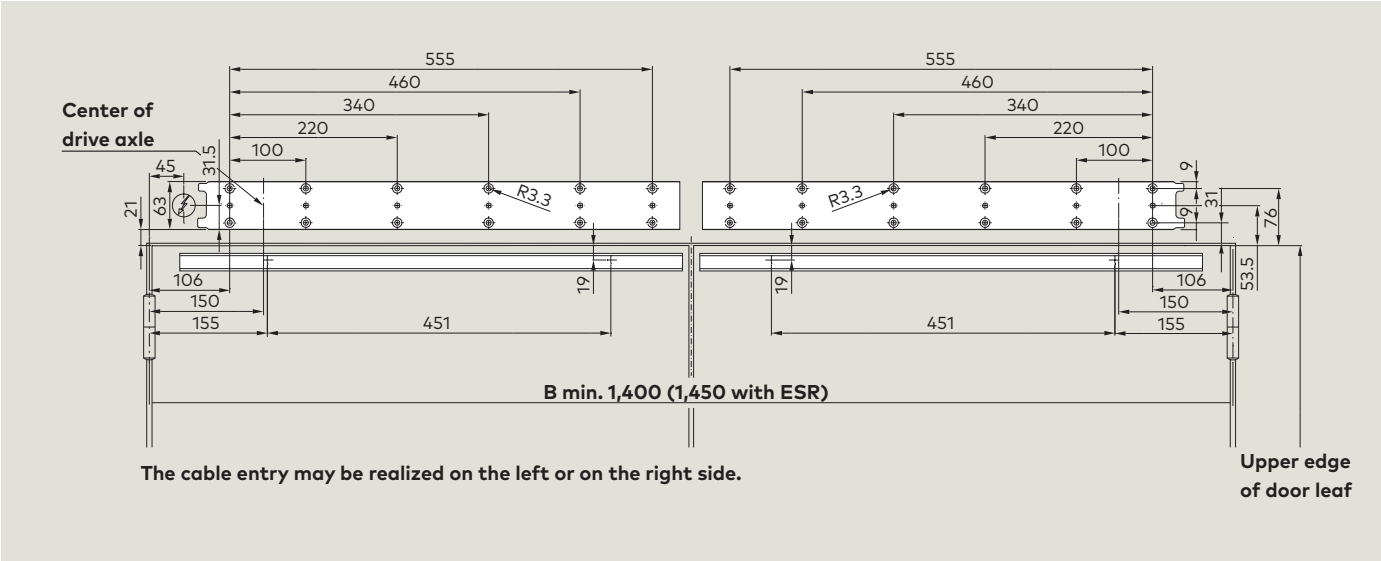

Drilling template: PROFESSIONAL cover, pull-version, 25 mm pivot pin, standard axle extension

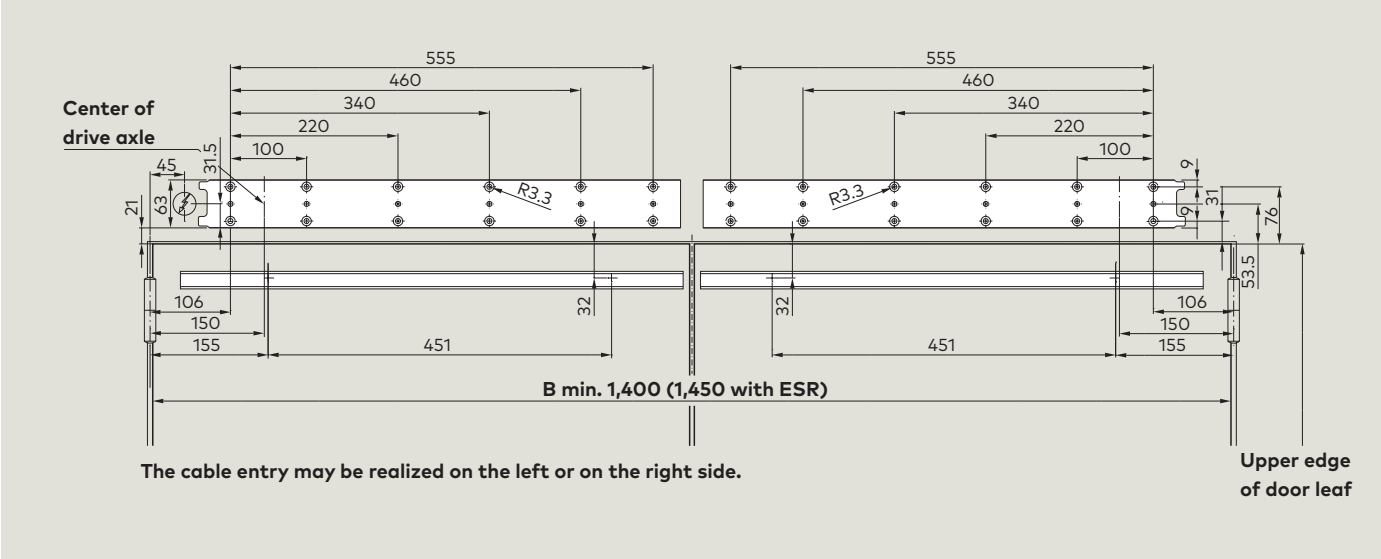

**View: PROFESSIONAL cover, push-version, CPD arm, 12.5 mm pivot pin, standard axle extension**

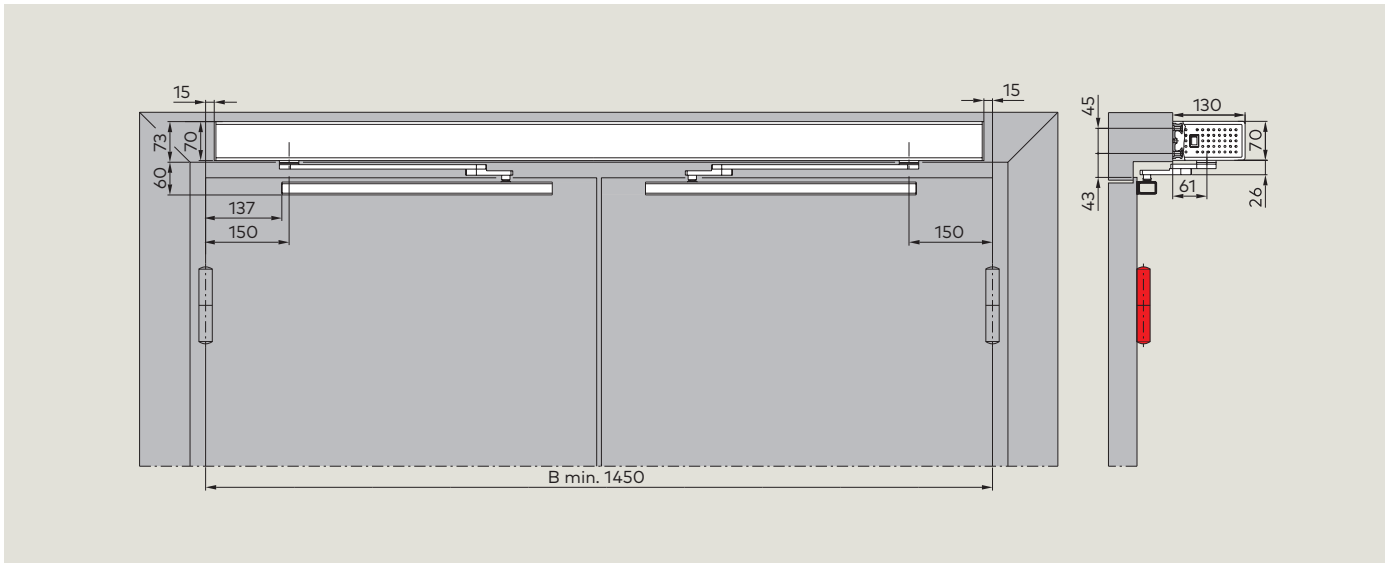

**View: PROFESSIONAL cover, push-version, CPD arm, 25 mm pivot pin, standard axle extension**

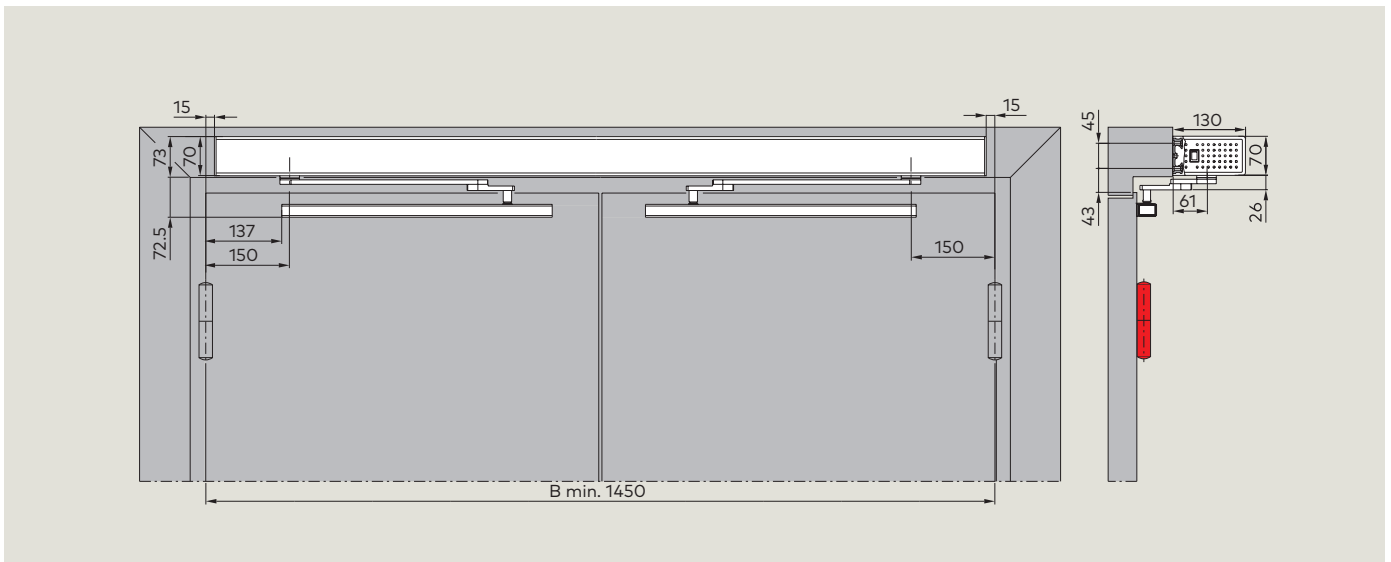

Drilling template: PROFESSIONAL cover, push-version, CPD arm, 12.5 mm pivot pin, standard axle extension

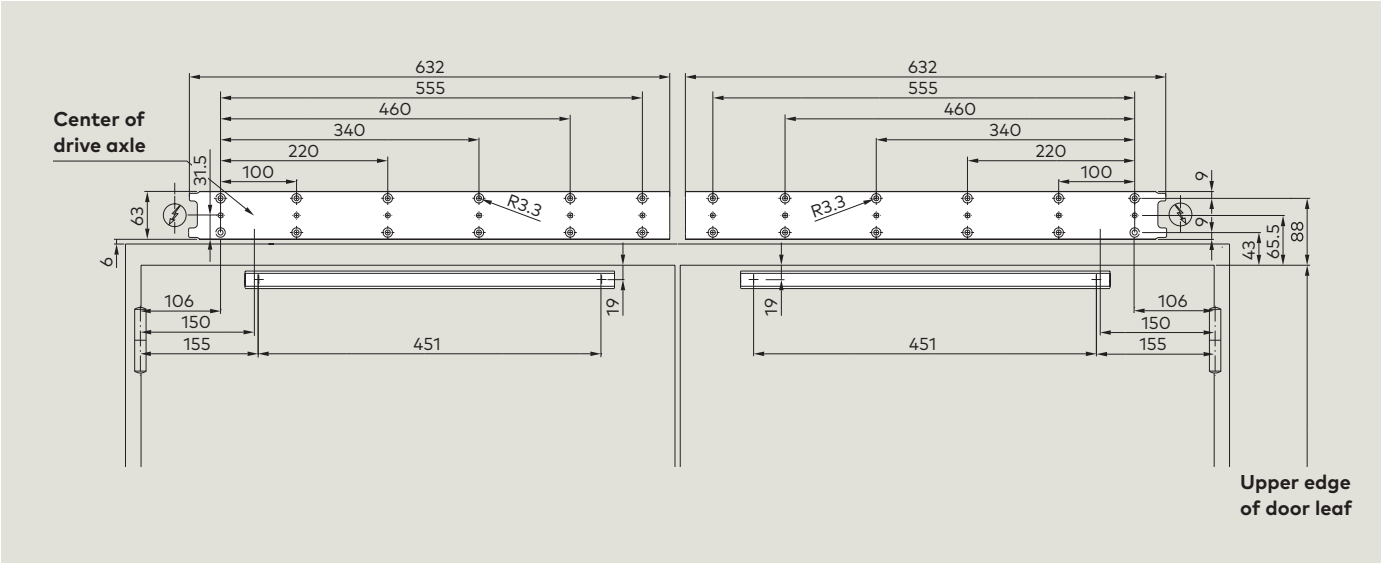

Drilling template: PROFESSIONAL cover, push-version, CPD arm, 25 mm pivot pin, standard axle extension

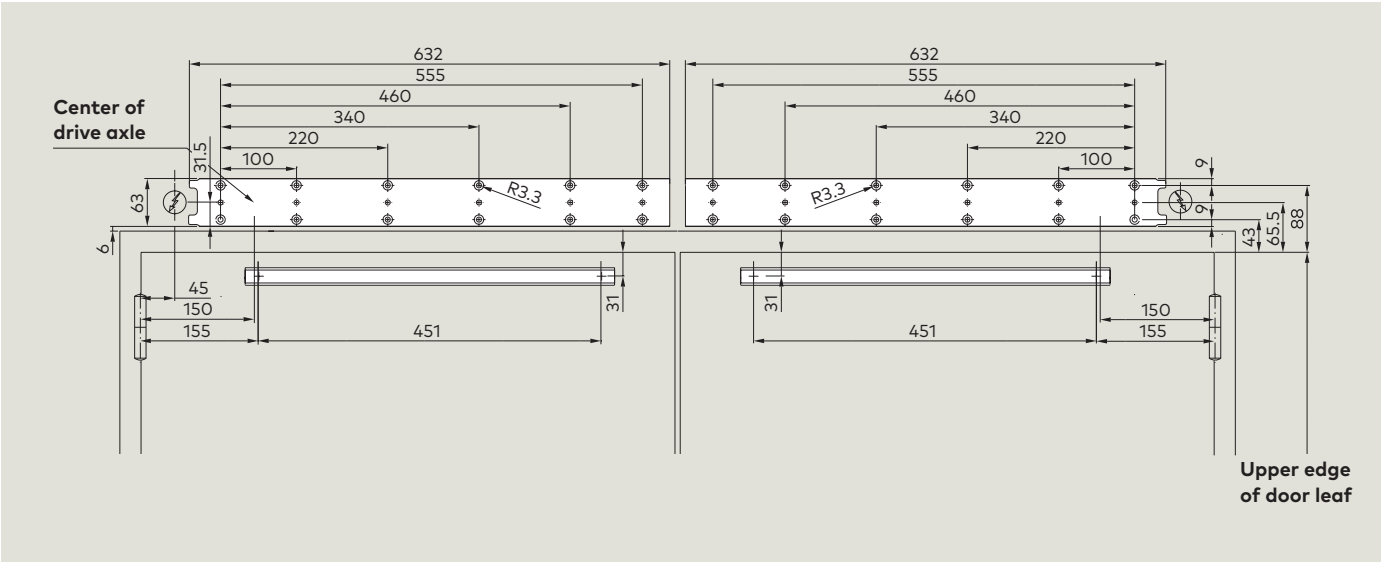

**View: PROFESSIONAL cover, push-version, 12.5 mm pivot pin, standard axle extension**

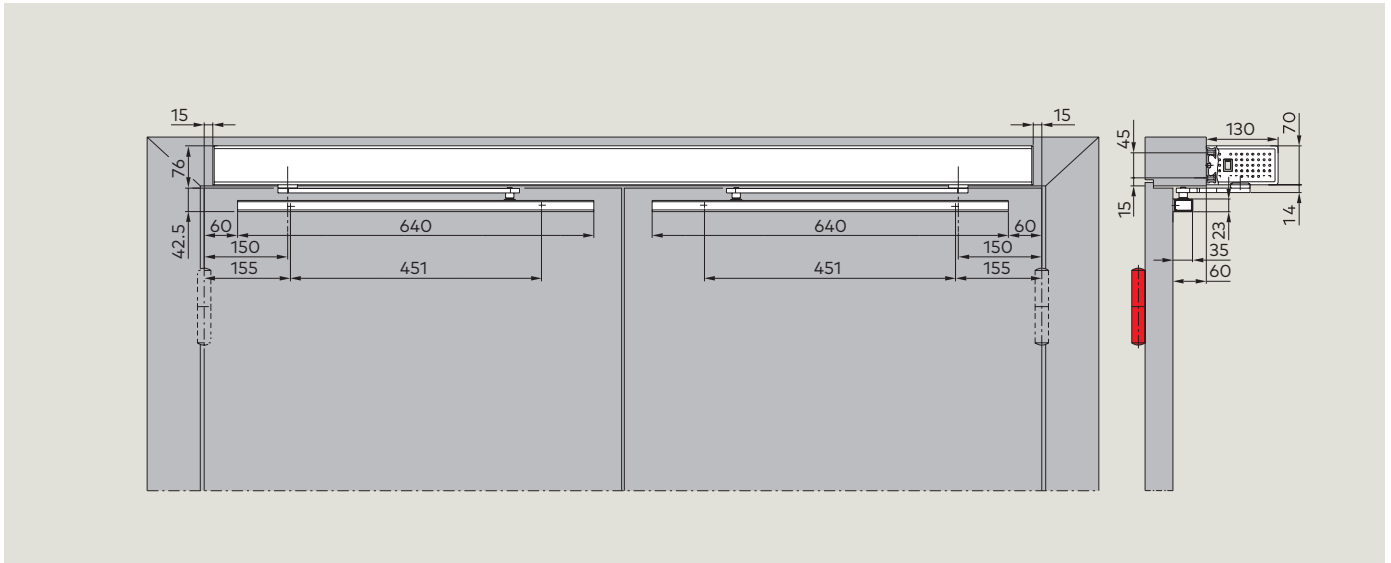

The push-version with slide channel is not suitable for smoke control doors and fire doors

**View: PROFESSIONAL cover, push-version, 25 mm pivot pin, standard axle extension**

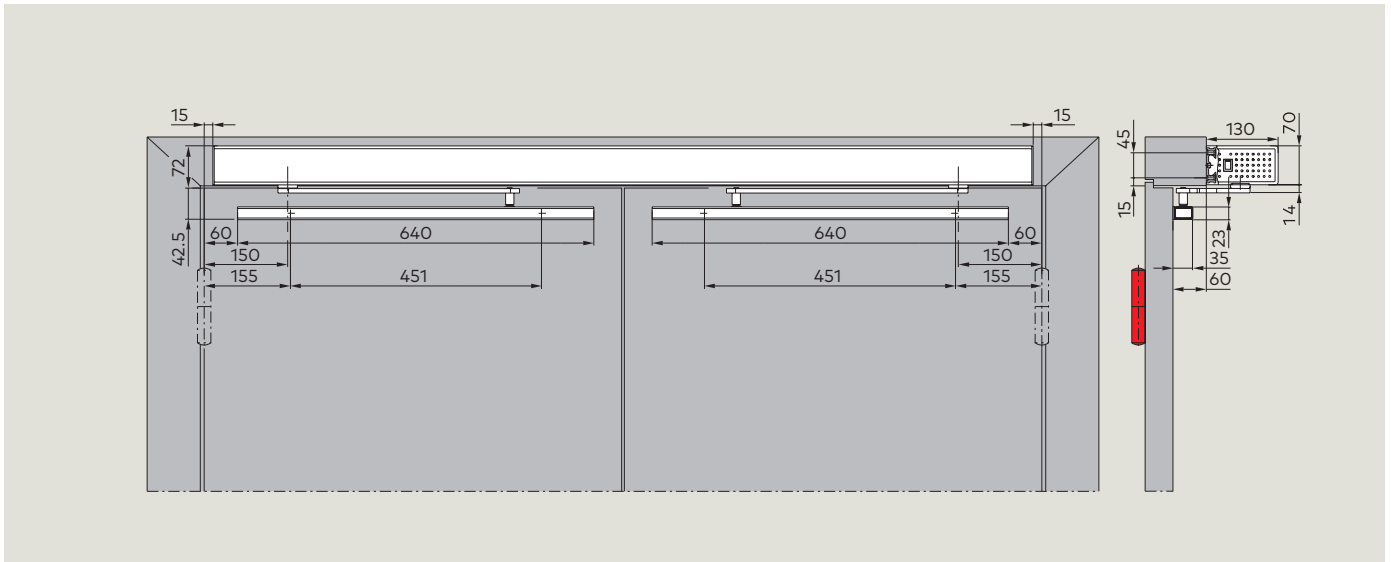

The push-version with slide channel is not suitable for smoke control doors and fire doors

**View: PROFESSIONAL cover, push-version, standard axle extension**

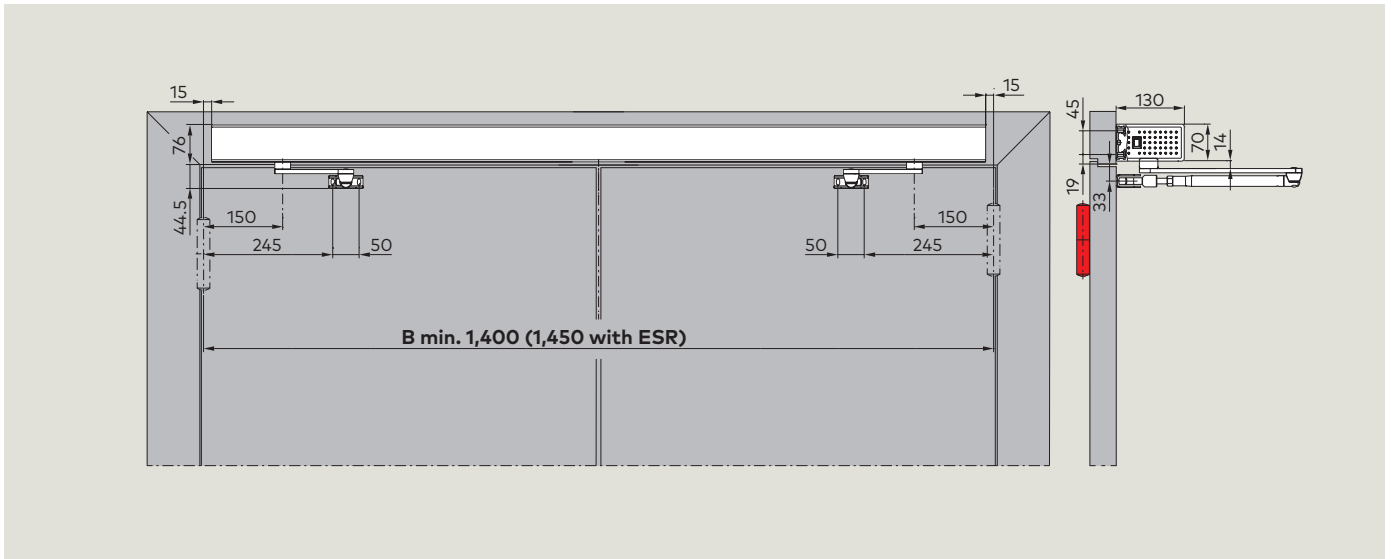

**Drilling template: PROFESSIONAL cover, push-version, 12.5 mm pivot pin, standard axle extension**

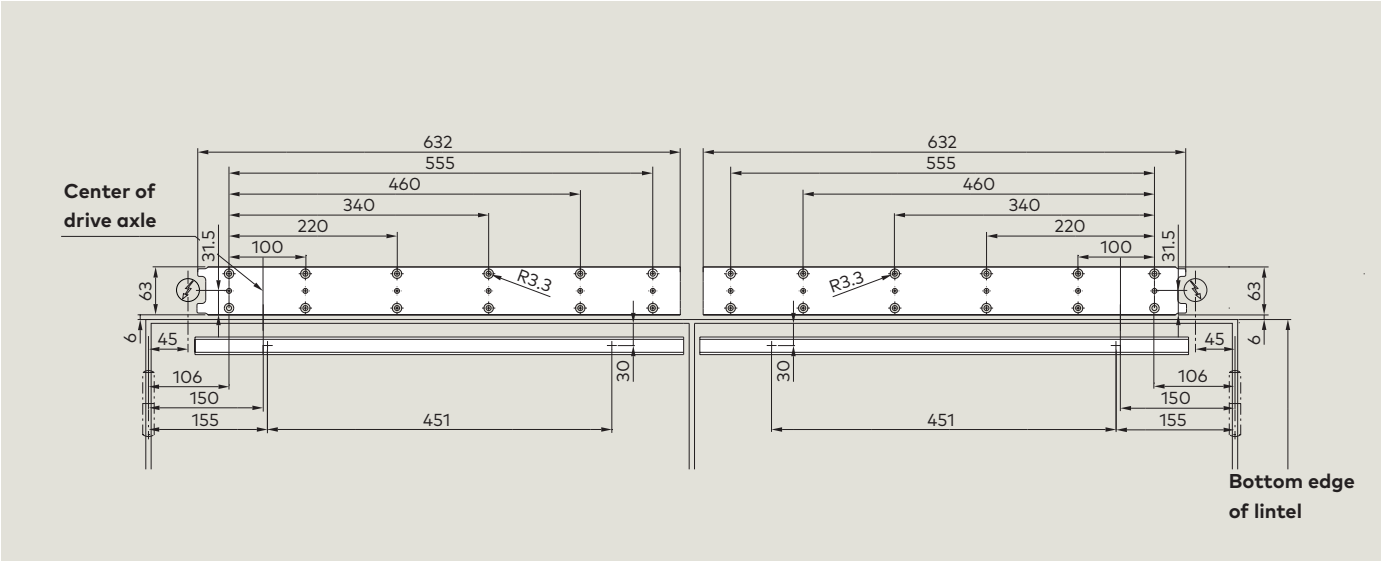

The push-version with slide channel is not suitable for smoke control doors and fire doors

**Drilling template: PROFESSIONAL cover, push-version, 25 mm pivot pin, standard axle extension**

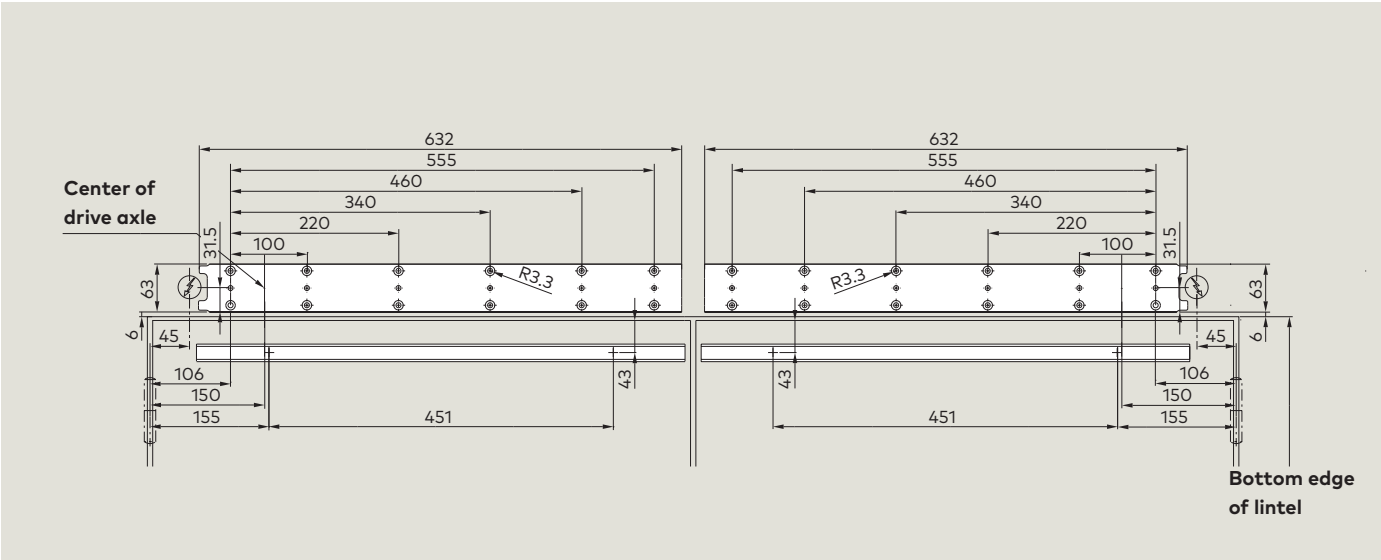

The push-version with slide channel is not suitable for smoke control doors and fire doors

**Drilling template: PROFESSIONAL cover, push-version, standard axle extension**

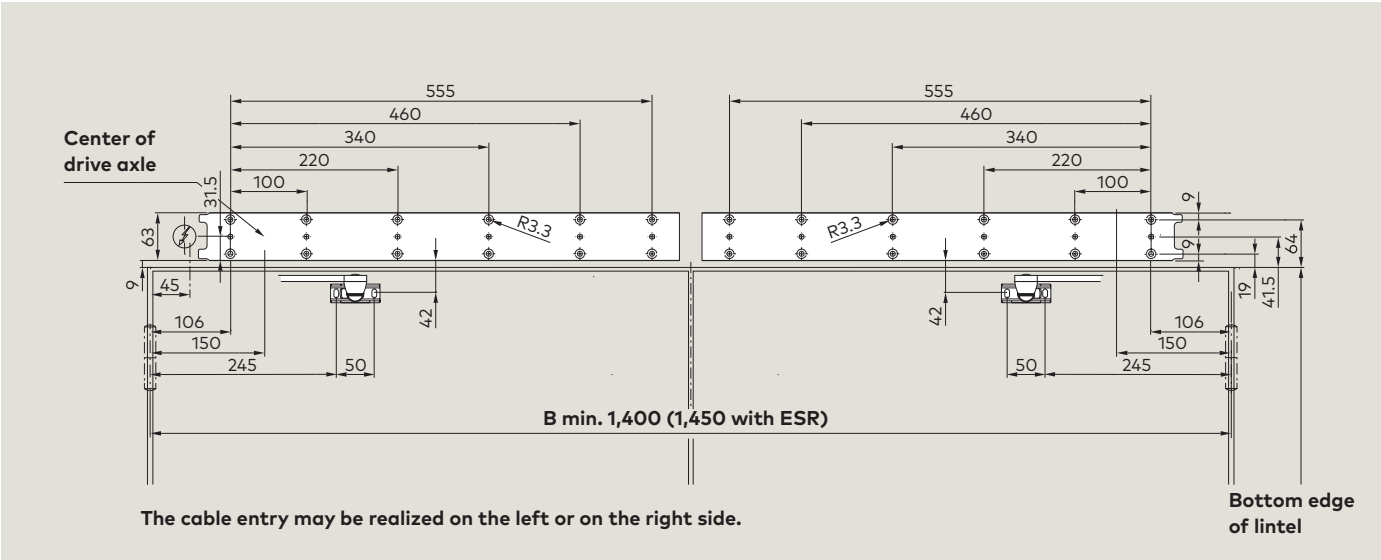

The cable entry may be realized on the left or on the right side.

## System setup

The example system is equipped with all available components. It is selected in accordance with the door-leaf width and the door-leaf weight.

- 1 Mains connection
- 2 Connection unit
- 3 Axle connection on both sides
- 4 Drive system (motor/gear/spring)
- 5 Adjustment of closing force
- 6 Control unit
- 7 Switching power supply unit
- 8 Slot for dormakaba Upgrade Cards
- 9 User interface with information display
- 10 Internal program switch
- 11 Slide channel (set)\*
- 12 Slide channel CPD (set)\*
- 13 Standard arm\*
- 14 Complete cover\*

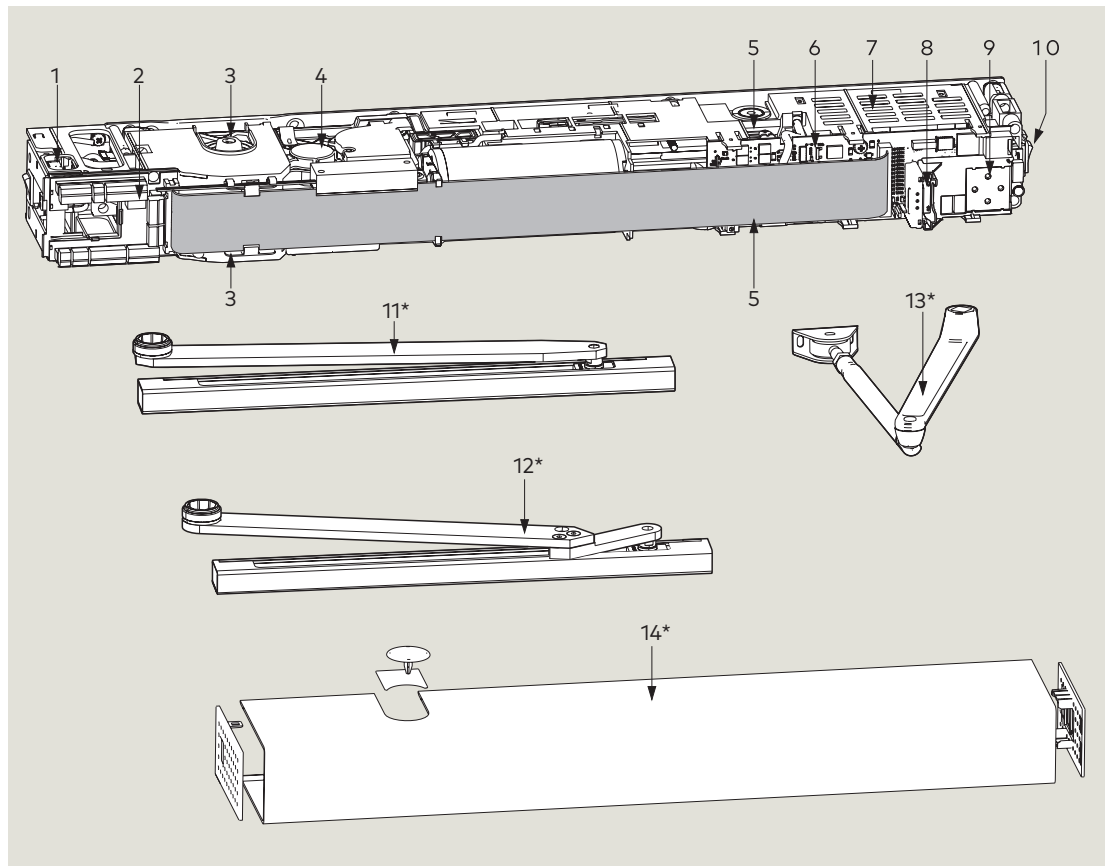

\*supplied separately

System	Specification	Order No.
ED 100 swing door drive 230 V	EN 2 - 4, push-version, fire protection; EN 2 - 4, pull-version, fire protection	29222301
ED 250 swing door drive 230 V	EN 4 - 6, push-version, fire protection; EN 4 - 6, pull-version, nor special requirements	29202301
	EN 4 - 6; pull-version; fire protection	29202302
	EN 4 - 5; pull-version; fire protection	29202303
ED 250 swing door drive PA	EN 4 - 6, push-version, fire protection; EN 4 - 6, pull-version, fire protection	29202305

### Partly automated two-leaf doors with ED 250 Power-Assist (PA)

In case of two-leaf doors, both door leaves are usually automated. However, it is often sufficient to have only one door leaf automated for passenger traffic. In that situation, the ED 250 PA in combination with a standard ED 100 or ED 250 will come into play and offer a cost-effective solution.

The ED 250 PA is used on the inactive leaf in case of two-leaf doors. While the active leaf can open fully automatically, the inactive panel is opened only manually and functions as a door closer. Optionally, the Power Assist function allows for an easy opening. However, the integrated locking device allows you to lock both door panels to a permanent open state without the use of any additional components.

The ED 250 PA is suitable for fire and smoke control doors and be combined with the ED ESR set for an ED ESR 1/2 for two-leaf doors. An upgrade card is not required for the ED 250 PA.



## Opening and closing torque

Way of mounting	Lintel mounting on hinge side with slide channel (pull-version)				Lintel mounting on opposite hinge side with standard arm (push-version)/ slide channel (push-version)			
	ED 100		ED 250		ED 100		ED 250	
	minimum	maximum	minimum	maximum	minimum	maximum	minimum	maximum
Closing force EN 1154	EN 2	EN 4	EN 4	EN 6	EN 2	EN 4	EN 4	EN 6
Manual closing torque (Nm)***	13	34	26	65	13	37	26	70
Closing torque in AUTOMATIC mode (Nm)**	20	FE: 150 LE: 67	20	FE: 150 LE: 67	20	FE: 150 LE: 67	20	FE: 150 LE: 67
Manual opening torque (Nm)	30	50	55	85	35	55	60	90
Opening torque in AUTOMATIC mode (Nm)**	20	FE: 150 LE: 67	20	FE: 150 LE: 67	20	FE: 150 LE: 67	20	FE: 150 LE: 67
Opening force with activated Power Assist function (N) *	23	23	23	23	23	23	23	23

**FE** = With Full-Energy or Fire Protection Upgrade Card, **LE** = Low-Energy standard drive without upgrade card

\* Power-Assist function is adjusted to maximum (function is activated at 0° opening width)

\*\* The torque is activated by an automatic opening in AUTOMATIC mode.

\*\*\* By installing the push-version with slide channel, the forces are reduced by approx. 33%

## Door closer mode & AUTOMATIC mode

Users may choose between two operation modes: door closer and AUTOMATIC mode. While adjusted to door closer mode (parameter Hd = 1), the system is optimized for manual operation. With its optional Power-Assist function, the door closer mode is tailored to predominantly manually-operated doors where a door closer function is desired.

The AUTOMATIC mode (parameter Hd = 0) in turn is especially suitable for mainly automatic access via motion detector or pushbutton.

In addition, the door reverses as soon as it runs into an obstruction while closing. On activation of the AUTOMATIC mode, also the wind load control is available. Although in AUTOMATIC mode, the doors are still ready for manual access. In this case we would recommend the Push & Go function.

## Wind load control

ED 100 and ED 250 drives are especially suitable for application at exterior doors that are subject to varying wind loads and for interior doors separating rooms where different pressure prevails. While the system is in AUTOMATIC mode, the wind load control monitors the driving speed and adjusts the speed correspondingly if it exceeds or falls below the adjusted value.

In conjunction with the Full-Energy Upgrade Card, the drive provides a force of up to 150 N at the main closing edge – which is then used to compensate environmental influences.

The electronic latching action is activated during the last 5° of the closing cycle in order to support the closing action.

## Power-Assist function

The Power-Assist function may be activated while the door is in door closer mode (parameter Hd = 1). As soon as a user opens the door by some degrees, the servofunction supports the manual opening cycle. In addition, the servo support automatically adapts to the adjusted size of the door closer. The level of servo support is adjustable in order to meet the requirements of DIN 18040, DIN Spec 1104, CEN/TR 15894, BS 8300/2100 and document "M", even up to class EN 6. The smallest adjustable opening torque amounts to 23 Nm/5 lbf – unless the hold-open device is triggered or in the event of a power failure. With the aid of the Power-Assist function, the system meets the

requirements of the European standard EN 1154 and provides barrier-free access during standard operation. However, it is not possible to use the system in conjunction with the Push & Go function or the wind load control as these functions may affect the easy manual opening of the door.

## Covers

The drive covers are packed separately from the drive system, which makes it easy to select the respectively required cover. dormakaba provides covers for single- and double-leaf systems. All covers are designed for on-site mounting and realized in dormakaba Contur design. They are furthermore suitable for both the ED 100 and the ED 250 version.

When creating double-leaf systems, the four-position internal program switch has to be replaced by a three-position switch, which means that the EXIT ONLY function is only available in combination with the external program switch. Double-leaf systems are required for doors where the clearance between the hinges exceeds 1,400 mm (1,450 mm with ESR).

### ED BASIC cover – Aluminum cover for single-leaf swing door systems

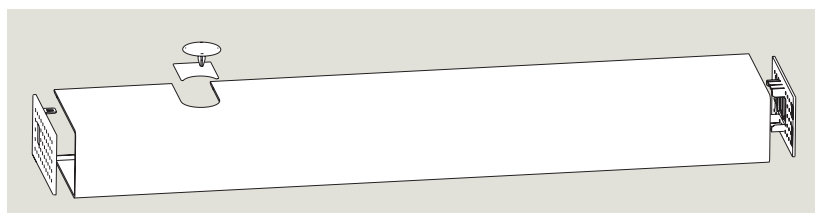

	Color	Order No.
ED BASIC cover	silver-colored	29241001
	white	29241002
	special color	29241003

### ED VARIO cover

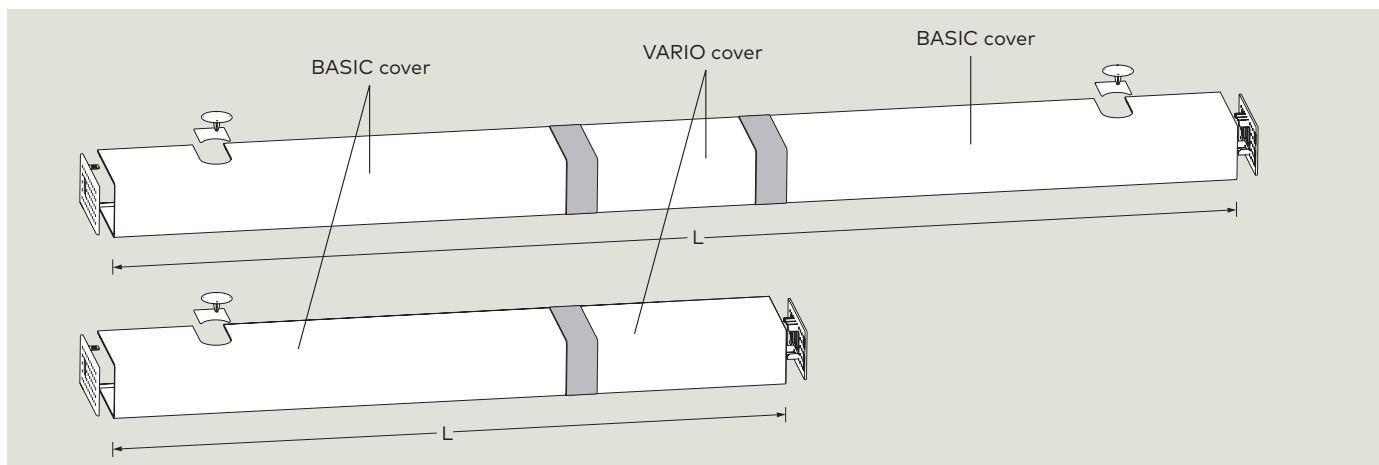

This aluminum cover is designed to create a continuous cover for double-leaf swing door systems. In addition to the VARIO cover, you will require two ED BASIC covers, which are mounted on the right and on the left of the drive system. The ED VARIO cover is designed to hide the gap between the two covers and may be sawed to the appropriate size on site. With the aid of the VARIO cover, you may also increase the length of single-leaf drives. The cover may be installed on the left or on the right side and can be sawed to the appropriate size on site. The VARIO cover is silver-colored and available in two versions.

Number of door leaves	Silver-colored	Order No.
<b>single-leaf version</b>		
800 mm – 1,600 mm	2,200 mm	29242001
<b>double-leaf version</b>		
1,500 mm – 2,200 mm	2,200 mm	29242001
1,500 mm – 2,800 mm	2,800 mm	29242002

### ED PROFESSIONAL cover

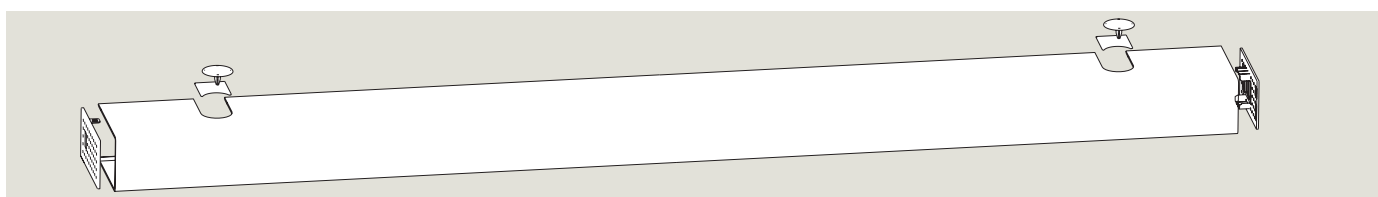

This aluminum cover is designed to create double-leaf swing door systems. The ED PROFESSIONAL cover is a continuous and seamless cover and available in lengths from 1,400 mm (1,450 mm with ESR) to 3,200 mm. With the PROFESSIONAL cover, also single-leaf drives may be extended to a length of up to 3,000 mm towards the main closing edge.

	Color	Order No.
ED PROFESSIONAL cover	silver-colored or as special color	29243003

# Arms

## ED slide channel set

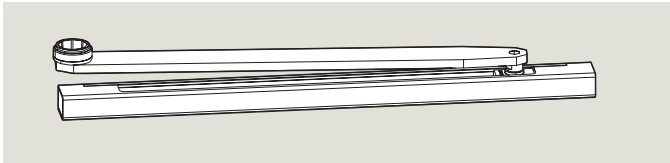

ED 100 and ED 250: For lintel depths +/- 30 mm

## ED slide channel set CPD

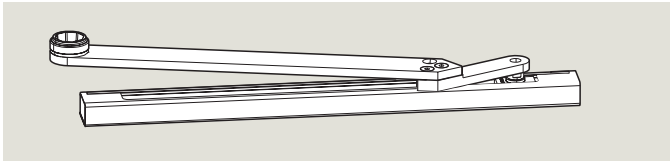

ED 100 and ED 250: For lintel depths 30 - 60 mm

## ED standard arm 225

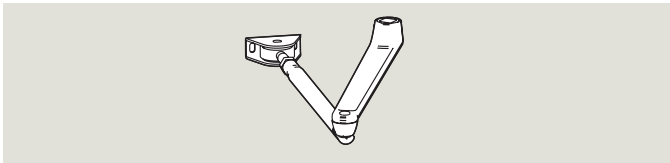

ED 100 and ED 250: For lintel depths 0 - 225 mm

## ED standard arm 500

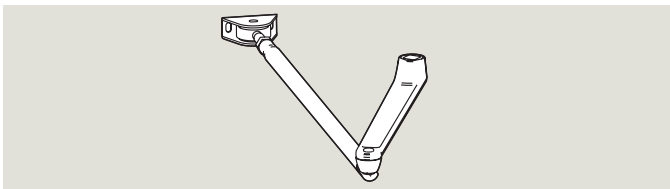

ED 100: For lintel depths 226 - 300 mm  
 ED 250: For lintel depths 226 - 300 mm and 250 kg  
 For lintel depths 301 - 500 mm and 160 kg

## ED axle extensions

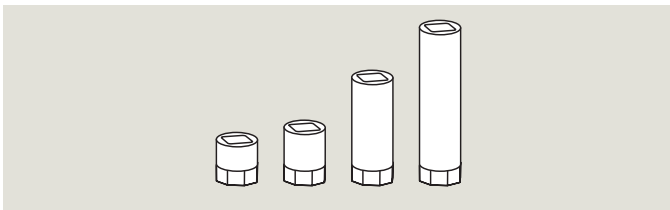

Mounting version	Color	Order No.
Pull- and push-version*	silver-colored	29275001
	white	29275002
	special color	29275003

\*The push-version is not suitable for smoke control doors and fire doors

Mounting version	Color	Order No.
Pull-version	silver-colored	29276001
	white	29276002
	special color	29276003

Mounting version	Color	Order No.
Push-version	silver-colored	29271001
	white	29271002
	special color	29271003

Mounting version	Color	Order No.
Push-version	silver-colored	29272001
	white	29272002
	special color	29272003

The axle extensions 20, 30 and 60 mm are suitable for all arm versions of the ED 100 & ED 250. The axle extension 90 mm is only suitable for all arm versions of the ED 250.

The axle extensions are available in chromated black.

ED axle extension	Order No.
20 mm	29278301
30 mm	29278001
60 mm	29278101
90 mm	29278201

## dormakaba Upgrade Cards

dormakaba Upgrade Cards are designed to increase the functional range of our swing door drives. The installation of the cards is very easy: Just insert the respective Upgrade Card into the proper slot at the control unit and the software will be transferred automatically.

dormakaba offers different Upgrade Cards, which may either be combined or installed as individual components. Please note that the respective function of the Upgrade Card is only available as long as the card is connected to the control unit.

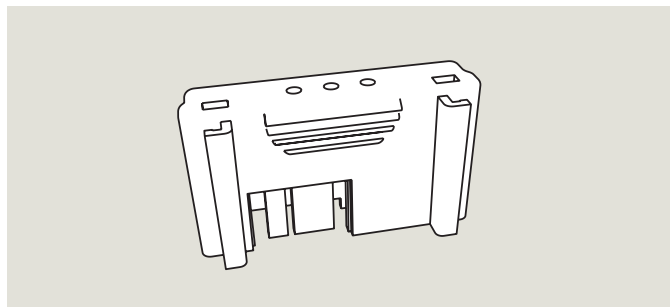

### Upgrade Card Full-Energy – blue

All drive systems are supplied as Low-Energy version, which means that the adjustable opening and closing speed range is restricted to a certain limit. The respective limits depend on the prevailing door-leaf width and door-leaf weight and may vary between 1° and 27° per second. These limits furthermore comply with DIN 18650 and EN 16005 (German Industrial Standard), ANSI 156.19 (American Standard) and BS 7036 (British Standard). Depending on their field of application, such swing door drives might not require safety sensors when operated in Low-Energy Mode. If you need a higher driving speed, you will require the respective Full-Energy Upgrade Card. The driving speed may then be increased to a maximum of 50°/second with the ED 100 and to 60°/second with the ED 250. In this case the swing path has to be monitored by safety sensors (mounted onto the door leaf).

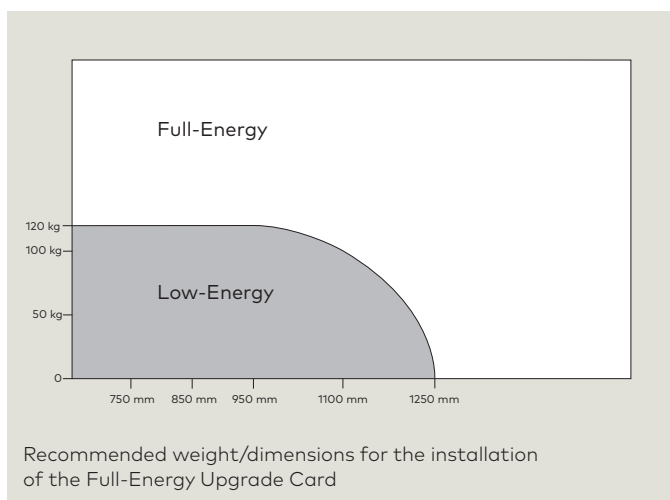

ED Upgrade Card Full-Energy	Color	Order No.
ED 100	blue	29251022
ED 250	blue/ transparent	29251020

### Upgrade Card Fire Protection ED 100 – red

When the ED 100 is installed at fire and smoke doors with application in preventive fire protection, the Upgrade Card Fire Protection is required for compliance with the guidelines for hold-open devices. Apart from its smoke detector connection (as monitored current loop), the card also offers a manual reset function (by opening the door), a full-energy function and the system may be triggered at the door leaf. Thanks to the card's integrated full-energy function, no additional Full-Energy Upgrade Card is required.

#### Manual reset by opening the door

A triggered hold-open system has to be reactivated manually. As soon as the function has been activated, it suffices to open the door until it has almost reached the adjusted opening width.

#### Triggering at door leaf

It must be possible to trigger a hold-open device manually in order to close the door. With ED 100 & ED 250, users may deactivate the hold-open function by a slight push against the door leaf. So no pushbutton is required to trigger a closing cycle; however, it is still available as an option.

ED Upgrade Card Fire Protection	Color	Order No.
ED 100	red	29252022
ED 250	red/ transparent	29252020

### Upgrade Card Professional

The Upgrade Card Professional provides functions for swing door drives that used to be realized with the aid of external components.

#### Extended hold-open time of 180 s

The hold-open time of up to 30 seconds, which is already integrated in the basic system, is sufficient for most applications. However, an extended hold-open time of up to 180 seconds may easily be realized with the aid of the Full-Energy Upgrade Card.

#### Flip-Flop function

In standard mode, the drive opens the door after a Night-/Bank pulse has been triggered (via the key switch) and closes it on expiry of the hold-open time. When the flip-flop function is activated, the door opens and remains in PERMANENT OPEN position as soon as the Night-/Bank function is triggered at the respective input. The door will close when the Night-/Bank function is activated again. The hold-open period in PERMANENT OPEN position is not limited, and the standard hold-open time is available at all other activator inputs. Please note that smoke detectors always have priority to the PERMANENT OPEN function.

#### Nurse-Bed function

(only for double-leaf door systems) As soon as a pulse is triggered, both door leaves of the double-leaf system will open. Sometimes this may not be necessary, as the full passage width is not required. Whenever this is the case, the nurse-bed function is perfectly suitable to control the two door leaves separately. The activator that is connected to the external detector only institutes the active door leaf to open. The resulting passage width is sufficiently big to allow people to use the door. The other activator (the one that is connected to the internal detector) is used to open the door to the full opening width. In this case, both door leaves open so that the full passage width is accessible. This function reduces the energy consumption and may help to avoid draughts and thus heat loss.

### Upgrade Card DCW®

The Upgrade Card DCW® provides the drive with a DCW® Bus connection. The integrated DCW® driver supports the following accessory:

#### Emergency exit motor lock with self-locking action SVP DCW®

The required procedure is controlled by the drive while the drive and the motor lock communicate via the DCW® bus.

#### ST 32 DCW®

The key switch to trigger the Night-/Bank function is suitable for application as activator outside the secured area (if you turn the key clockwise). When the key switch is used in conjunction with the DCW® program switch: the program switch is adjusted to OFF by turning the key counter-clockwise in order to deny access after closing of business or during work breaks. Turn the key to the right for more than 3 seconds in order to trigger the AUTOMATIC function.\*

	Color	Order No.
ED Upgrade Card Professional ED 100 & ED 250	green	29253001

	Color	Order No.
ED Upgrade Card DCW® ED 100 & ED 250	yellow	29254001

\* Depending on regional standards, provisions and regulations regarding the safeguarding of buildings, further measures to shut off the building may be required.

## Upgrade Card barrier-free toilet

With the aid of the Upgrade Card, the required special functions are allocated to the in- and outputs of the control unit to facilitate the connection of the respective components.

### System overview

The system requires an electric strike, a motor lock or similar devices to keep the door closed. Furthermore, the door is equipped with a lever handle on the inside and a knob on the outside so that the door may only be opened from the inside and the outside with the corresponding key. In addition, large-surface pushbuttons are installed on the inside and on the outside of the toilet while a status indicator (vacant/occupied) on the outside and an occupied light indicator on the inside of the toilet indicate the current status. As an option, we provide an emergency pushbutton (to be mounted on the outside), which allows to open the door immediately in the event of an emergency.

Please note that dormakaba recommends connecting the barrier-free toilet to an additional emergency call system (by others).

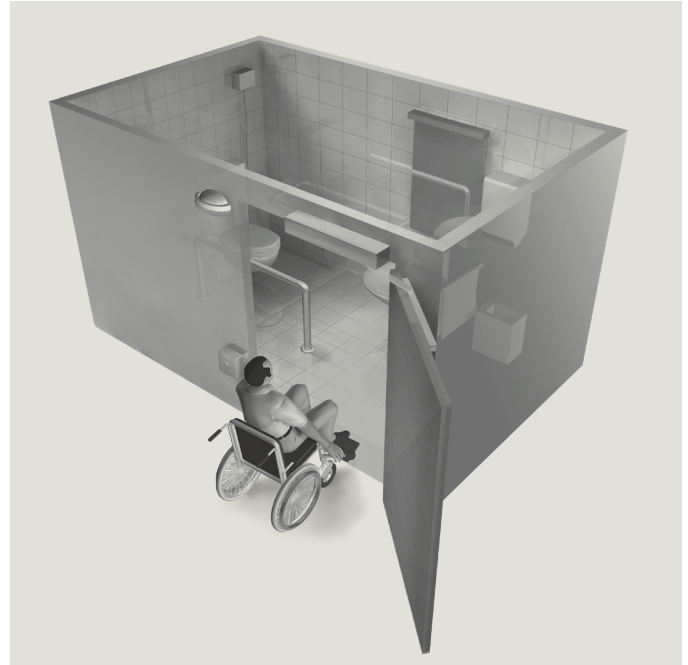

### Entering the barrier-free toilet

While the toilet is vacant, the status indicator on the outside is green. Use the pushbutton on the outside to trigger an automatic opening cycle. The door will close automatically on expiry of the adjusted hold-open time. As soon as the door is fully closed, users may deactivate the external pushbutton via the pushbutton on the inside so that the door is no longer accessible from the outside. At the same time, the external status indicator switches from green to red in order to indicate that the toilet is occupied. Also the internal status indicator turns red to show the user inside the toilet that the door is now locked.

### Leaving the barrier-free toilet

Users may open the door either automatically via the internal pushbutton or manually by using the lever handle. At the same time, the system emits a 24 V DC message, which may be used to flush the toilet automatically. The door closes on expiry of the adjusted hold-open time. The status indicator on the outside switches from red to green and the light indicator on the inside goes out as soon as the door has reached its "closed" position.

### Emergency opening from the outside

The system is ready for connection of an emergency pushbutton so that, in the event of an emergency, users may deactivate the locking function and the door can only be opened by hand. In this case the door no longer operates automatically.

As an alternative, the door may be opened with the aid of a key from the outside (in the event of an emergency). In both cases, the status indicator on the outside switches from red to green and the light indicator on the inside goes out.

---

#### Order No.

---

Upgrade Card  
Barrier-Free Toilet

29253002

---

# Operating as Hold-Open System

## Functional characteristics

In the event of a fire, the ceiling-mounted or lintel-mounted smoke detectors detect emitted smoke and deactivate the automatic opening of the door. In this case, the drive will close the door via the integrated spring and can no longer open it automatically. Apart from the automatic activation via smoke detector, the system may also be triggered manually via the optional manual release pushbutton or when the door is closed by hand. In order to reactivate the system, the door has to be opened manually.

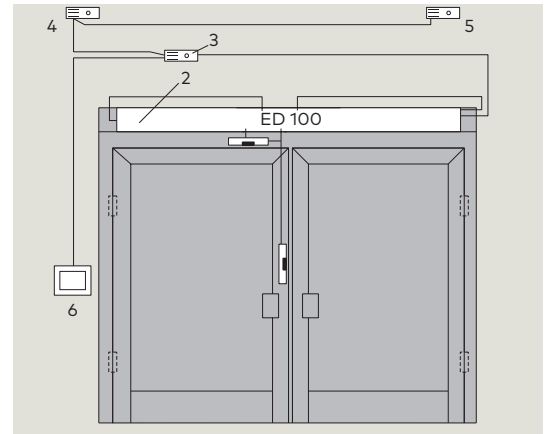
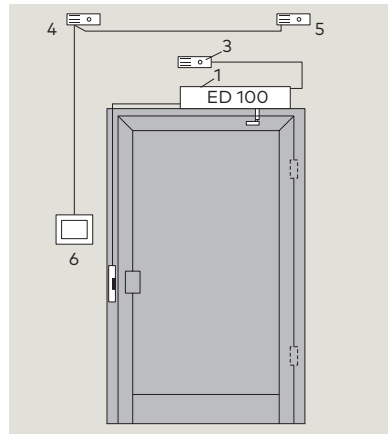

- 1 ED 100/ED 250
- 2 ED 100/ED 250 with continuous cover
- 3 RM-ED smoke detector

- 4 RM-N smoke detector, opposite hinge side
- 5 RM-N smoke detector, hinge side
- 6 Optional manual release pushbutton "Tür zu" (German for "close door")

## RM-ED lintel-mounted smoke detector

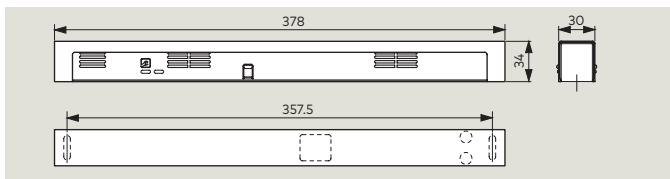

	Color	Order No.
RM-ED	silver-colored	64840001
	white	64840011
	special color	64840009

## RM-N ceiling-mounted smoke detector

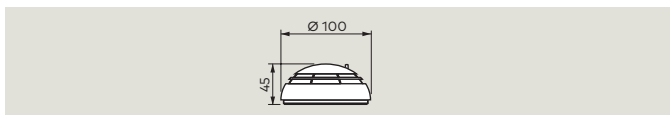

	Color	Order No.
2 x RM-N	white	64830900

## HT manual release pushbutton

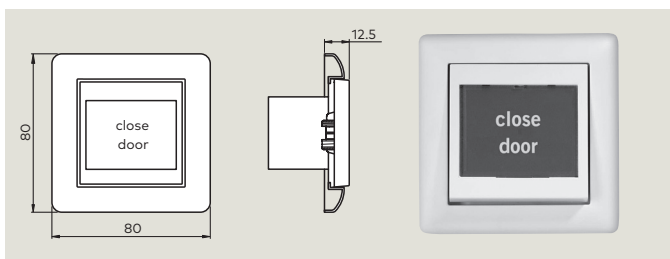

	Color	Order No.
Flush-mounted version	white	19144601175
Box for surface-mounting for HT (No picture)	white	05158533332

## ESR – Integrated door coordinator

The ESR set is installed inside the double-leaf drive on site. It is available as individual component and easy to install. The system works similar to a drum brake and thereby ensures the proper functioning of the system. Its brake works on the motor shaft of the drive on the active door leaf and transfers the switching signal via a shaft. The system does not require any maintenance.

	Order No.
ED ESR set	29261001

## Wiring diagrams

### ED 100 & ED 250 single-leaf doors

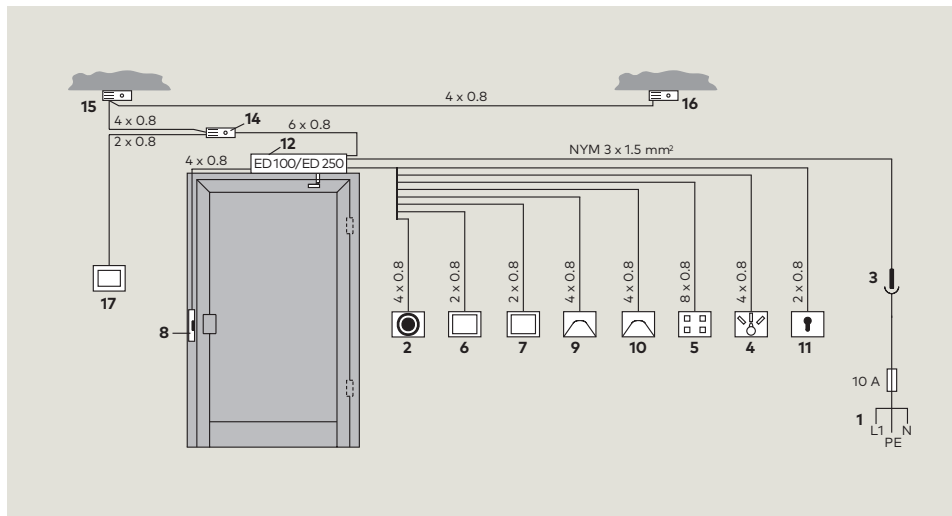

#### Connections

- 1 Power supply
- 2 Emergency pushbutton, function: Emergency Off
- 3 Two-pole-and-earth socket
- 4 External PGS, mechanical
- 5 External PGS, electronic
- 6 Pushbutton, inside
- 7 Pushbutton, outside
- 8 Locking device
- 9 Radar motion detector, inside
- 10 Radar motion detector, outside
- 11 Key switch
- 12 ED 100/ED 250
- 13 ED 100/ED 250 with continuous cover
- 14 RM-ED smoke detector
- 15 RM-N smoke detector, opposite hinge side
- 16 RM-N smoke detector, hinge side
- 17 Optional manual release pushbutton "Tür zu" (German for "close door")
- 18 Red-green-display

### ED 100 & ED 250 double-leaf doors

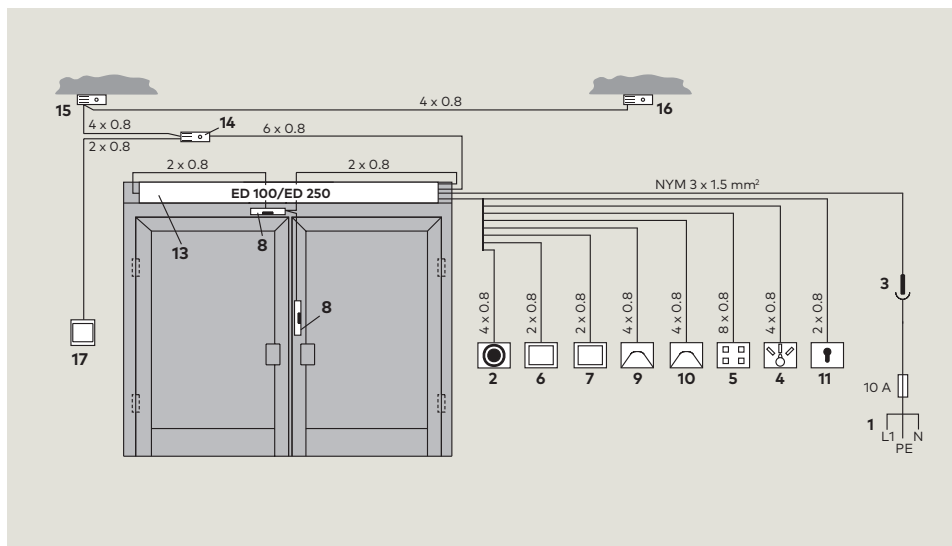

### ED 100 & ED 250 single-leaf doors, barrier-free toilet

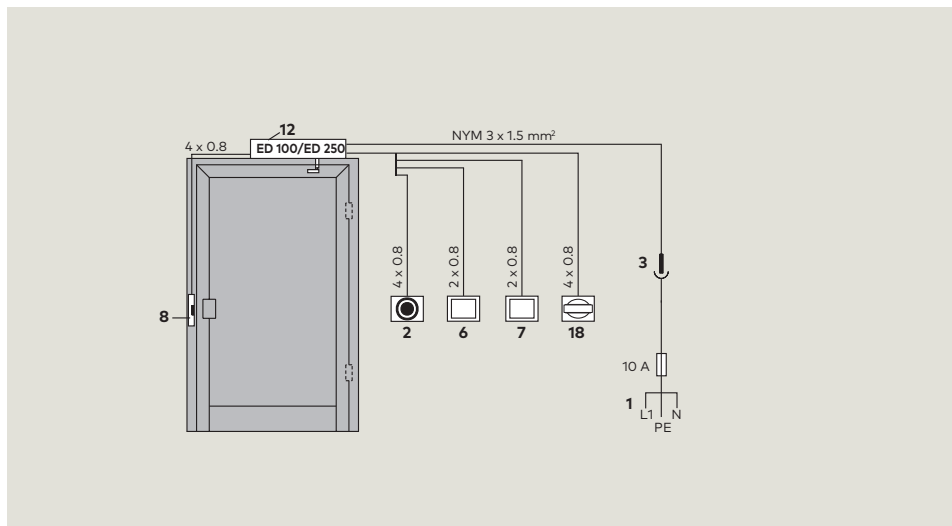



## Program switches

External program switches are available in different designs and have been conceived for all kinds of demands. They offer various options, from a mechanical to a full-electronic version, alternatively also

lockable via profile half-cylinder or in a full-electronic way via code. These switches are designed to replace the internal program switch.

### Mechanical

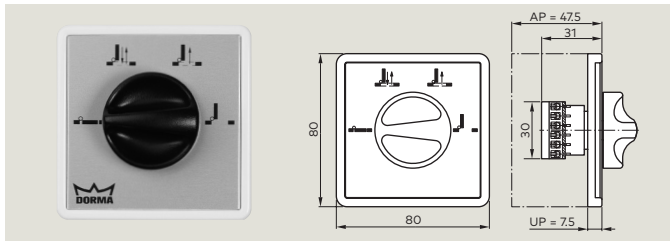

Program switch	Color	Order No.
4-position, aluminum, flush-mounted version	white, Gira S-Color	19135404150
Box for surface-mounting		5080531332

### Mechanical and lockable

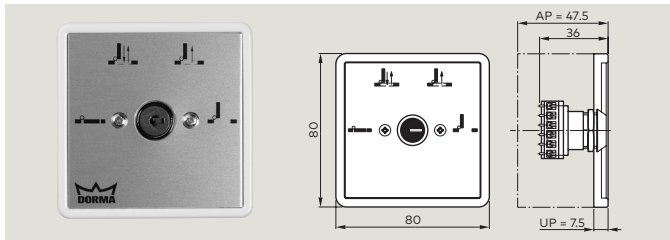

Program switch	Color	Order No.
4-position, lockable, aluminum, flush-mounted version	white, Gira S-Color	19135604150
Box for surface-mounting		5080531332

### Electronic

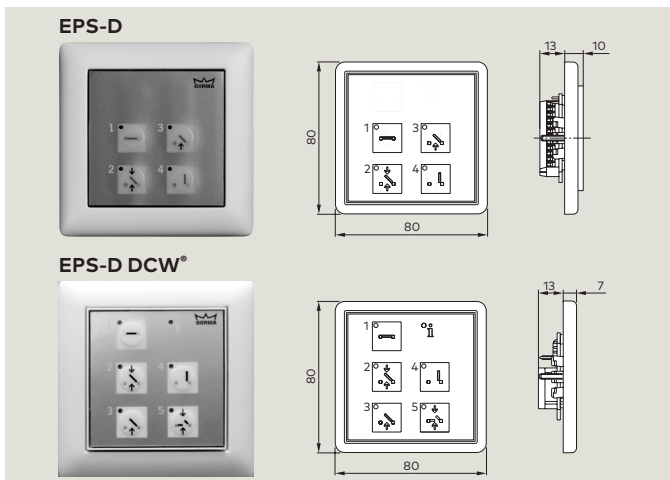

Full-electronic Program switch	Color	Order No.
... control up to 5 different functions of the automatic door: Off, automatic, exit only (closing time), partial open (1-panel opening in case of 2-panel doors), permanent open. Electronically operated via push buttons. Lockable via numerical code or an additional key switch. DCW® model can be controlled centrally, e.g. from a PC, function display is simultaneously visualized on the program switch. System 55, flush-mounted		
EPS-D	white	16557001150
EPS-D DCW®	white	16577301150
Box for surface-mounting		5158533332

### Mechanical with profile half-cylinder

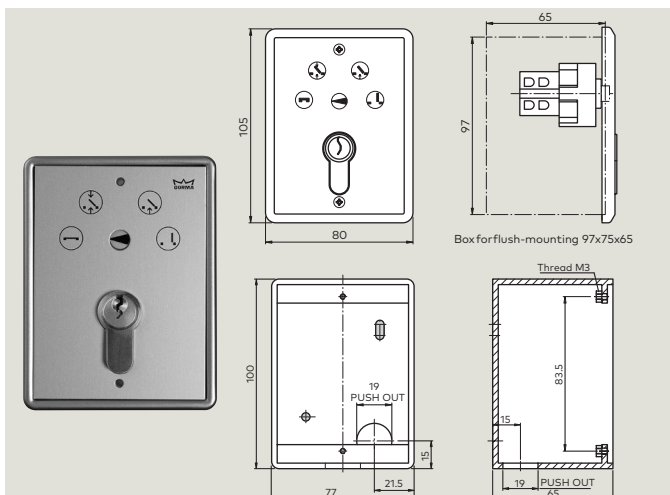

Program switch	Color	Order No.
4-position, lockable via profile half-cylinder, white, flush-mounted version	white	19141801170
Box for surface-mounting		19142201170

## Pushbuttons

### Pushbutton

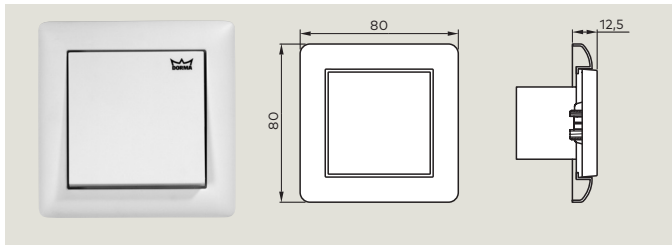

	Color	Order No.
Single-pole changeover contact, standard frame, flush-mounted version, System 55	white	19144701170

### Key switches KT 3-1 surface-mounted version/flush-mounted version

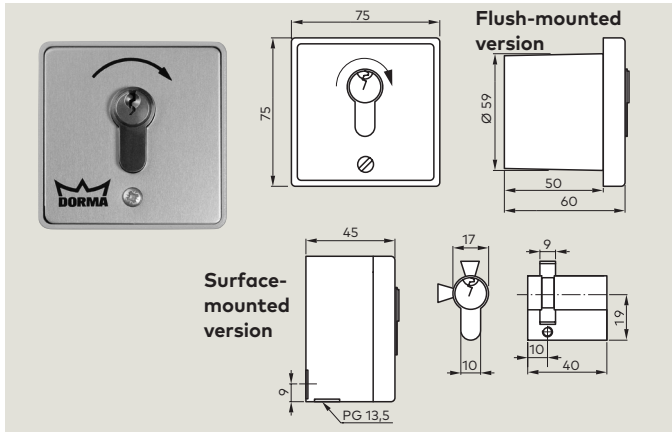

	Order No.
1 NO contact, with profile half-cylinder (may be replaced by any standard profile half-cylinder), key only retractable in neutral position, aluminum, metal, 75 x 75 x 60 mm	
KT 3-1 flush-mounted version	05054531332
KT 3-1 surface-mounted version	05054631332

### Key switches ST 32 DCW®

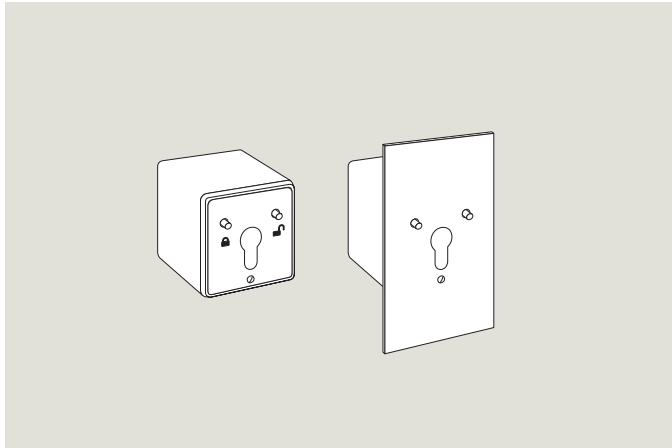

	Order No.
Tamper-proof key switch with LED display (red/green), silver-colored LM housing with front plate, suitable for surface-mounted and flush-mounted installation, for controlling the door management system TMS. Adjustable and restrictable functions of the key switch ST 3x DCW® can be programmed via the parameterization software, TMS Soft. Connection to the door management system TMS via DCW® system bus. Protection class IP 54. Dimensions (W x H x D) (approx.): Housing: 75 x 75 x 50 mm Front plate (flush-mounted installation): 90 x 100 x 2 mm.	56343200

### CT 4/1 code keypad as control for locking devices

(keypad and electronic module have to be combined)



The code keypad does not require optional software for simple access authorizations. The water resistant metal keypad is also suitable for installation in the exterior of a building. Thanks to Plug & Play, the 4- or 6-digit code may be changed directly with the aid of the keypad.

The respective control unit is installed within the security zone and may be connected to all dormakaba drives. Surface-mounted version, 230 V/50 Hz, 1.5 V A, 1 x UM potential-free relay contact 8 A, 250 V, connections: max. 2.5 mm, 75 x 75 x 11.5 mm

	Color	Order No.
MTB 4/1 metal keypad to enter the activation code (to open the door) and for programming purposes, surface-mounted version 75 x 75 x 11.5 mm		05079331332
EB 4/1 Electronic module, incl. 2 m connection cable, plastic cover, surface-mounted version	black	05063431332

## Pushbuttons (elbow)

### Large-sized pushbutton (elbow)

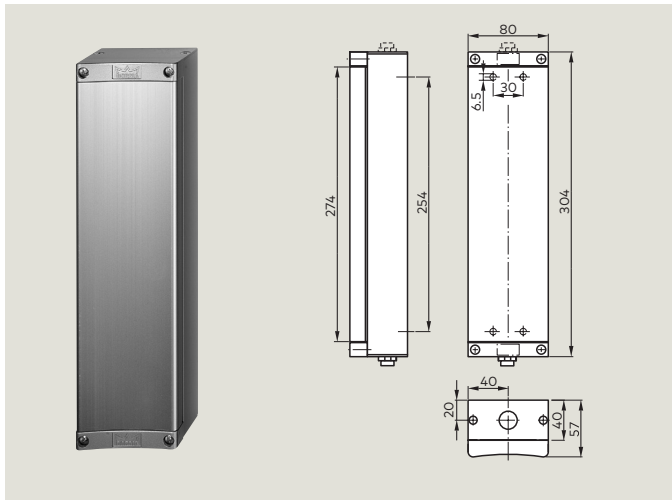

	Color	Order No.
Flush-mounted version/ surface-mounted version, 304 x 80 mm	silver-colored	90410015

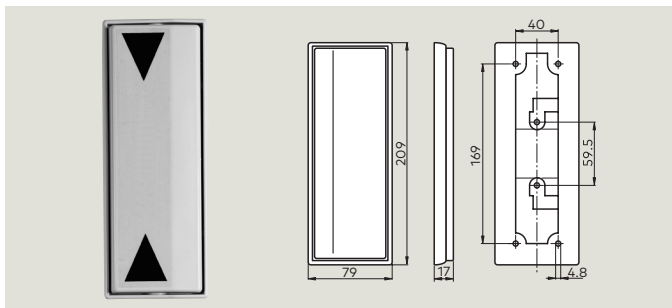

	Color	Order No.
Surface-mounted version, flat design, plastic, 209 x 79 x 17 mm	grey	05080231332

### Large-sized pushbuttons

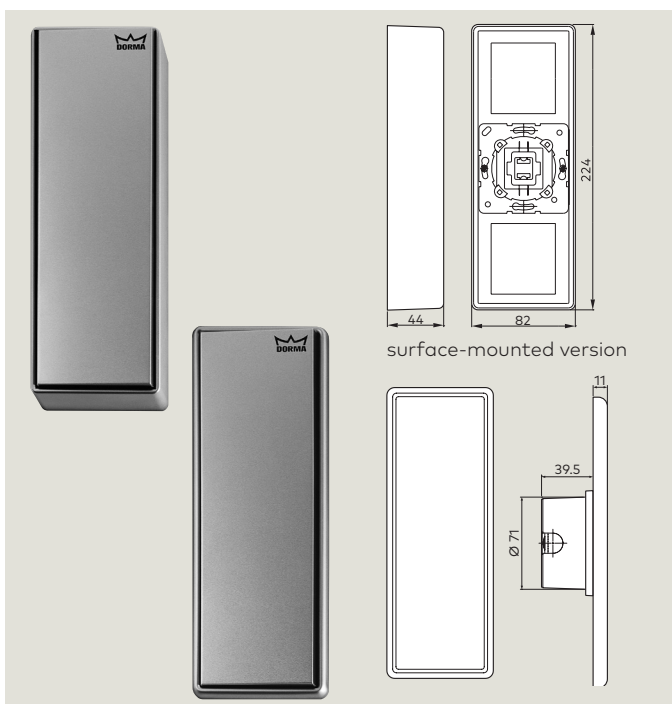

Large-sized pushbuttons	Color	Order No.
With box for flush-mounting, without switch pad, incl. switch, 224 x 82 mm	silver-colored	05095531332
With box for surface-mounting, without switch pad, incl. switch, 224 x 82 x 44 mm	silver-colored	05095231332

Switch pad	Order No.
Stainless-steel, suitable for surface-mounted version/ flush-mounted version, 214 x 70 mm	05095431332
Stainless-steel, suitable for surface-mounted version/ flush-mounted version, 214 x 70 mm, lettering "Tür auf" (German for "open door") (No picture)	05095331332

## BRC remote system

The new BRC system operates with a bi-directional BidCoS wireless protocol. In contrast to unidirectional systems, the receiver sends a message to the hand-held transmitter that the signal has been received. The hand-held transmitter indicates the prevailing status via a LED. Thus a short keystroke is enough to trigger an opening pulse in a reliable way within the system's typical field range of 100 meters.

The BRC-W and BRC-T transmitters are also of bi-directional design; however, the status indicator is not visible as the transmitters are integrated in pushbuttons.

### BRC-R

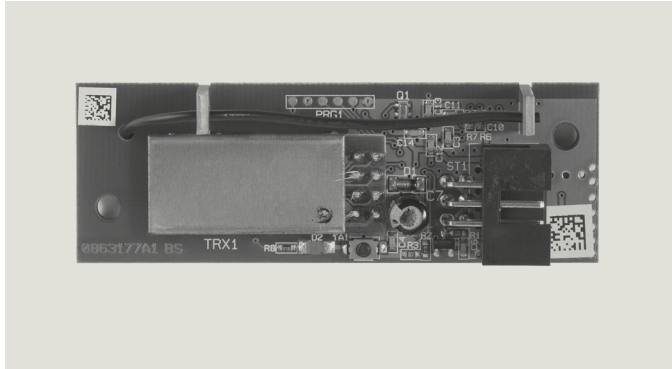

The BRC-R radio receiver may easily be installed inside the drive as its size is adapted to the available space. Simply fix it on the motor-gear-unit with two screws.

We offer three different types of transmitters. Up to 1024 transmitters may be allocated to a BRC-R.

---

#### Order No.

Receiver	29302002
----------	----------

### BRC-W



The battery-operated wall-mounted transmitter can easily be glued or screwed to the wall.

The push button can also be installed without the frame into existing switch series System 55. Suitable for the interior under lighter conditions.

---

#### Order No.

Wall transmitter	29301002
------------------	----------

required battery type: 2 x 1.5 V LR03 (AAA)

### BRC-H 3



Bidirectional hand-held transmitter BRC-H, battery-operated, 4 channels, LED for feedback purposes, shockproof design.

---

#### Order No.

Hand-held transmitter	29304001
-----------------------	----------

required battery type: 1 x 1.5 V LR03 (AAA)

### BRC-T



Battery-operated transmitter, designed for installation into a pushbutton with deep box for flush-mounting or into a surface-mounted large-sized pushbutton. In connection with the dormakaba stainless-steel large-sized pushbutton it is also suitable for heavier conditions.

---

#### Order No.

Battery-operated transmitter	29301003
------------------------------	----------

# The complete solution

Automatic entrance systems require careful specification and installation to ensure safety and reliability in use. Commencing with a risk assessment survey, dormakaba will advise at all stages of design and installation so the correct methods of operation and user safety protection are adopted.

## Risk Assessment

All automatic doors must be specified and installed following appropriate safety standards requiring risk assessment prior to installation and periodically during the life of the product. dormakaba are experienced with safety specification and can provide further details on request.

Professional and impartial advice from staff assessed and accredited by ADSA (Automatic Door Suppliers Association):

- Site surveys, escape routes, impaired user access.
- Risk assessment reports
- Consultation with leading safety bodies and equipment manufacturers.
- CPD delivery to specifiers and professional organisations



## Protection

Automatic doors installed in the UK are subject to the highest safety demands in accordance with EN 16005:2012. To meet these requirements consideration must be given to the use of barriers, self-monitoring sensors and other protective devices. These are mandatory for each door and uniquely specific to its location.

Advanced, standards-compliant technologies for all door types:

- Compact sensors with microwave Doppler technology for motion detection
- Combination sensors with active infrared technology for simultaneous motion and passageway protection
- Active infrared motion detectors based on the triangulation principle for protection of users or obstructions located in the door panel travel path
- Laser sensors with precision monitoring and extended field of view over the door face
- Barriers, fingerguards and appropriate signage for increased risk users, children or failsafe situations





# Activation

dormakaba automatic doors are designed and tested to meet a wide range of building entrance styles and user requirements. Access to the building can be controlled through a number of methods from simple switches and keylocks to intelligent access control readers.

Wide choice of access methods from dormakaba:

- Radar approach sensors, opening integrated with emergency escape systems
- Manual pushbuttons with high visibility and ease of use for disabled users.
- Access control readers using simple access fobs or fully integrated with a monitored access control system



# Maintenance

Automatic doors must be maintained and periodically assessed to be safety compliant. dormakaba have the UK's largest service network of trained engineers experienced on all types of door system both dormakaba and from other manufacturers.

Qualified service engineers assessed and accredited by ADSA:

- Scheduled maintenance visits and emergency callout.
- Risk assessment reports
- Trained and accredited service engineers with national coverage and logistic support



For further advice on dormakaba products and accessories please contact:

[info.gb@dormakaba.com](mailto:info.gb@dormakaba.com)

01462 477600



[www.dormakaba.co.uk](http://www.dormakaba.co.uk)

dormakaba UK & Ireland  
E: [info.gb@dormakaba.com](mailto:info.gb@dormakaba.com)  
Wilbury Way, Hitchin  
Hertfordshire  
SG4 0AB  
T: +44(0)1462 477600  
F: +44(0)1462 477601

WN 053741 51532, UK 06/2018  
Subject to change without notice