

Project-based Facade Fittings

Slide-Turn Window

Parallel Opening Louvre Window

Parallel Opening Window

Projecting Top-Hung Window



BAU 2015

January 19–24 · Munich



Project-based facade fittings

Window and facade elements fulfil a number of important functions as part of a building envelope: noise control, energy saving, comfort and ventilation efficiency to mention but a few.

In order to unite the aesthetics of the facade with of the energetic overall concept of the building, WSS has developed and implemented many innovative solutions for facade elements.

The slide-turn fitting for narrow, high window and louvre elements demonstrates one of these new developments. The essential feature is the concealed guide rail. Clever kinematics and high-quality plain bearings allow for safe and smooth operation.

Parallel opening windows (PAF) and projecting top-hung windows are the first choice for large window leaves. Leaf weights of up to 250 kg for parallel opening windows and up to 350 kg for projecting top-hung windows give architects and planners greater creative leeway. WSS has developed two new, patented, specialised stays for both fitting solutions. The double X-stay stabilises narrow parallel opening windows in particular. Despite the small installation width of only 150 mm for narrow elements, opening widths of up to 180 mm can be achieved. The second innovation for projecting top-hung windows: Thanks to the horizontal, swivel-mounted X-stay the leaf can be guided securely and achieve greater lateral stability.

Motorised control is an option for all models; thereby enabling integration into centralised building management in regard to the overall energy concept.

Demonstrating greatness – innovations from WSS

Content

Slide-turn Window	Page 4
Parallel Opening Louvre Window.....	Page 6
Parallel Opening Window	Page 8
Projecting Top-hung Window	Page 10



That speaks for us.



**KÖ-Bogen,
Dusseldorf**

Projecting top-hung
windows with heavy leaves



RWTH Aachen

Parallel opening windows
(motorised)



**Speditionsstraße,
Dusseldorf**

Projecting top-hung
windows with
heavy leaves



**Taunusturm,
Frankfurt**

Parallel opening
louvre windows



**Daimler-Chrysler,
Potsdamer Platz, Berlin**

Projecting top-hung
windows with
heavy leaves



**Deutsche Post,
Bonn**

Side-hung windows
(motor-controlled)



**Sony Center,
Berlin**

Projecting top-hung
windows
(4-point special stay)



**Neven DuMont,
Cologne**

Vertical sliding windows

Cleverly turned



Slide-turn Window

For narrow windows and ventilation louvres

Narrow and floor-to-ceiling window and louvre elements have proven themselves time and again for natural ventilation in modern facade technology. However, conventional fitting systems are considered to have a prominent appearance because of the integrated rail system. Complying with the requirements, a predominantly concealed solution has been developed that combines high ventilation efficiency, the necessary security against falling and aesthetic aspects.

The concealed slide rails are placed and limited to a 90° position by an inlaid guide rail and the connected control-arm. Thanks to the clever kinematics the leaf can be operated easily and safely with the stay-arm serving as a control element. The limited movement path enables maximum ventilation with the greatest degree of safety. At its opening position of 90° and at the locking position, the fitting complies with the DIN EN 12600 regulations for leaf widths with a clear opening of up to 320 mm.

The sliding carriage provides secure navigation of the element with smooth operation. The fitting is designed for a leaf weight of up to 50 kg and can be optionally upgraded to 100 kg.

The design is particularly suited for narrow, floor-to-ceiling ventilation elements. In contrast to conventional products, extremely narrow profiles can be realised thanks to the concealed guide rails and sliding carriage. The fitting is also visually upgraded as there are only delicate lines visible above and below that match the profile in colour and are hardly visible.

The new slide-turn fitting is system neutral and can be used for all standard window profiles.



Technical features:

Leaf height max. 2,600mm
Leaf width 300–500 mm
Leaf weight: 50 kg (optional up to 100kg upgradable)
Operation: manual

Special features:

- Can be used right/left
- Open leaf fall-security with a clear opening width of up to 320 mm
- Slide mechanism concealed in the profile
- Utilisation of standard window profiles
- Feasible for very narrow elements
- Easy and fast installation

We've got the hang of it!



Parallel Opening Louvre Window

Parallel projecting technology for excellent ventilation efficiency

The new fittings system for the parallel opening louvre window combines a parallel fitting with additional swivel technology. The leaf or louvre is moved inwards and downwards in an arc. As a result, the advantages of a circulating and safe ventilation function are combined with an increased ventilation cross section in the projecting element.

The new system is based on solid stainless steel opening levers, which replace the stay technology that was used up to now. The opening levers are fitted with an adjustable, integrated brake device.

A patented, swivel guide stay is used to ensure the safe opening of the louvres up to 250mm.

The opening lever mounting is concealed and the operating lever is installed flush, allowing the unassuming aesthetics of the overall element to be retained.

In the case of motor-controlled louvres, the drive is provided by spindle drives concealed in the louvre.



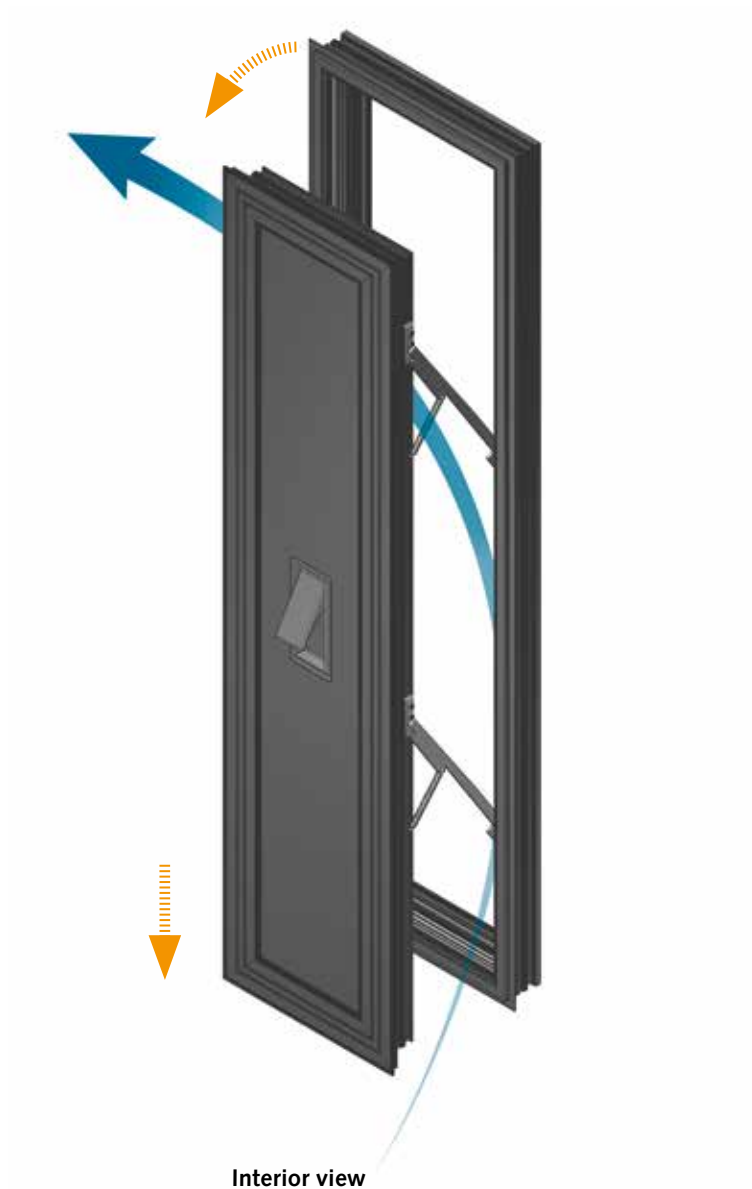

Technical features:

- Leaf size: max. LW = 500 mm/LH = 2,000 mm
- Leaf weight: max. 35 kg
- Opening width: max. 250 mm
- Required chamber dimension: min. 21 mm
- Operation: manual (1 handle)

Reference:

Taunusturm Frankfurt (special version)

Special features:

- The fittings system can be developed for lifting elements.
- All parts corrosion-resistant
- Spring-supported, cushioned opening possible

Parallel in standard profile

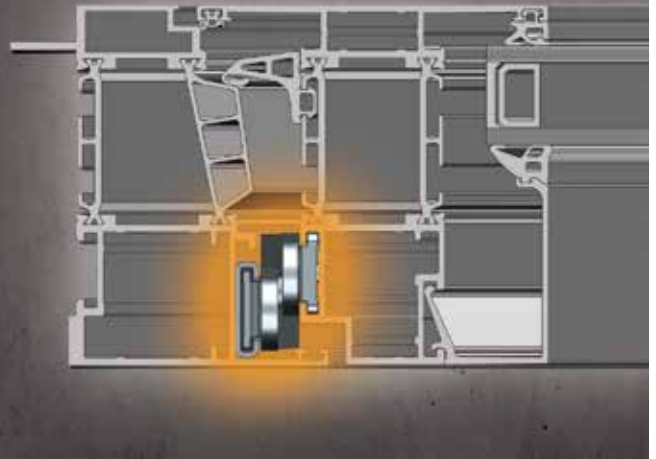

Parallel Opening Window

Complex stay technology for 16 mm profile chamber

The parallel opening window (PAF) is becoming more and more significant for property facades. The design as well as safety and noise protection requirements plus the complete circulating ventilation function are crucial for this fitting solution.

However, a number of systems can only be utilised in special profiles because of the large dimensions of the stays. That's why WSS has developed a stay geometry that only takes up a chamber dimension of 23 x 16 mm.

The combination of PX and PY stays and the compact stay design allows for secure and smooth movement of the leaf. High-grade materials and the resilient stay-mechanism mean that no compromises need to be made for various designs. Leaf weights of up to 150 kg (manual operation) can be easily realised with the standard design. The operation of larger leaves up to 250 kg is motorised.

The combination with the rod handle design line for wide leaves up to 1.350 mm is new. A smooth opening movement is ensured by the double-sided simultaneous activation of the concealed central gearing mechanism.

Another new development is the patented compact control-stay for very narrow ventilation elements.

The narrow design for installation areas larger than 150 mm permits opening widths up to 180 mm. The compact dimensions of the stay with 23 x 21 mm enables utilisation in standard profiles with minimal installation efforts.

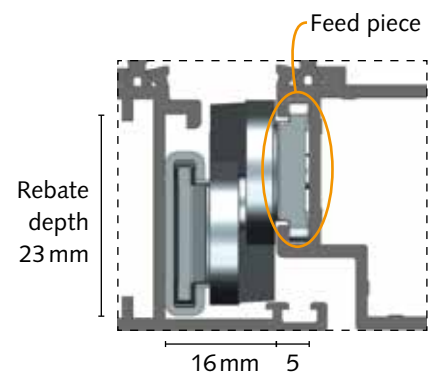

Profile section with stay



Compact control-stay



Axel Springer Verlag, Berlin



also available handle-operated

Technical features

- Leaf size: max. LW = 1,350mm/LH = 3,000mm
- Leaf weight: max. 250 kg
- Opening width: max. 200 mm
- Required chamber dimension:min. 16 mm
- Operation: manual (2 handles)

Reference:

IMS Bordeaux

Special features:

- The open leaf is secured by turning the handle. This also prevents the leaf closing of its own accord if it becomes windy (possible).
- Can be used in standard profiles due to compact design
- Larger leaf dimensions on request
- Motor-operated version available on request
- Stays can be synchronised with each other
- Additional horizontal locking possible
- All parts corrosion-resistant

Projecting and top-hanging for heavyweights



Projecting Top-hung Window

Solutions for large ventilation elements

The requirements of the modern facade are characterised by functional diversity in conjunction with the overall aesthetic appearance of the building envelope.

Large-scale facade elements with their corresponding leaf weights are therefore becoming increasingly popular. The projecting top-hung fitting, in particular, has additional technical features:

- An element opening outwards does not require any swivel room on the inside; therefore, room space can be fully utilised.
- All fittings, with the exception of the operating handle, are concealed.
- The fittings geometry optimises the ventilation principle, fresh air flows in from below and stale air is channelled out at the top.

WSS is introducing a projecting top-hung fitting that has been developed specially for extreme leaf sizes and leaf weights.

WSS has a patented solution for better stability of these large elements: The new, swivel-mounted control-stay serves to safeguard against sideward wind loads for high leaves.

The opening width at the bottom has been limited to 120 mm for safety reasons. Additional fall protection in line with DIN EN 13049 is available on request.

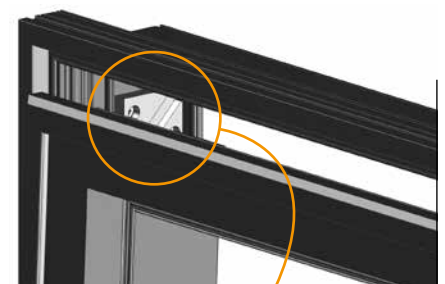

Detail leaf lowering



Daimler-Chrysler, Potsdamer Platz, Berlin



swivel-mounted control-stay



Technical features:

Leaf size: max. LW = 1,350mm/LH = 3,200mm
 Leaf weight: max. 350 kg
 Opening width: max. 120 mm (fall protection)
 Required chamber dimension: min. 21 mm
 Operation: manual
 Height adjustable: ±3 mm

Special features.

- Motor-controlled operation on request
- Larger leaf dimensions on request
- All parts corrosion-resistant

References:

Kö Bogen, Dusseldorf
 Petrom City, Bucharest
 Speditionsstraße, Dusseldorf
 Daimler Chrysler, Berlin
 Hypo AAC, Villach
 Stadthalle, Graz



Wilh. Schlechtendahl & Söhne
GmbH & Co. KG

Hauptstraße 18–32
42579 Heiligenhaus

P.O. Box 10 05 52 / 62
42570 Heiligenhaus

Phone: +49 (0) 20 56 / 17-0
Fax: +49 (0) 20 56 / 51 42

Web: www.wss.de
E-Mail: wss@wss.de

All image, product, dimension and design information is correct at the time of going to press. We reserve the right to make any changes that may be required for technical and further development. We assume no liability for printing or other errors. Legal claims, regardless of their nature, may not be inferred from the use of our documents. No part of this document may be reproduced without our prior written consent.